

1

Calculate:

a) $11 + 1 = 12$	b) $41 + 1 = 42$	c) $71 + 1 = 72$	d) $81 + 1 = 82$
$11 + 2 = 13$	$41 + 2 = 43$	$71 + 2 = 73$	$82 + 1 = 83$
$11 + 3 = 14$	$41 + 3 = 44$	$71 + 3 = 74$	$83 + 1 = 84$
$11 + 4 = 15$	$41 + 4 = 45$	$71 + 4 = 75$	$84 + 1 = 85$
$11 + 5 = 16$	$41 + 5 = 46$	$71 + 5 = 76$	$85 + 1 = 86$
$11 + 6 = 17$	$41 + 6 = 47$	$71 + 6 = 77$	$86 + 1 = 87$
$11 + 7 = 18$	$41 + 7 = 48$	$71 + 7 = 78$	$87 + 1 = 88$
$11 + 8 = 19$	$41 + 8 = 49$	$71 + 8 = 79$	$88 + 1 = 89$
$11 + 9 = 20$	$41 + 9 = 50$	$71 + 9 = 80$	$89 + 1 = 90$

2

Fill in the missing numbers.

a) $5 + 4 = \boxed{9}$	$15 + 4 = \boxed{1} \boxed{9}$	$95 + 4 = \boxed{9} \boxed{9}$
b) $3 + 5 = \boxed{8}$	$23 + 5 = \boxed{2} \boxed{8}$	$43 + 5 = \boxed{4} \boxed{8}$
c) $2 + 7 = \boxed{9}$	$32 + 7 = \boxed{3} \boxed{9}$	$82 + 7 = \boxed{8} \boxed{9}$

3

Which is more? How many more? Write in the correct signs and numbers.

a) $31 \boxed{<3} 34$	b) $42 \boxed{<3} 45$	c) $53 \boxed{<3} 56$
$22 \boxed{<4} 26$	$33 \boxed{<4} 37$	$44 \boxed{<4} 48$
$64 \boxed{<3} 67$	$55 \boxed{<4} 59$	$71 \boxed{<9} 80$

4

Fill in the missing numbers.

a) $7 - 4 = \boxed{3}$	b) $17 - 4 = \boxed{1} \boxed{3}$	c) $57 - 4 = \boxed{5} \boxed{3}$
$5 - 2 = \boxed{3}$	$25 - 2 = \boxed{2} \boxed{3}$	$65 - 2 = \boxed{6} \boxed{3}$
$8 - 6 = \boxed{2}$	$38 - 6 = \boxed{3} \boxed{2}$	$48 - 6 = \boxed{4} \boxed{2}$

1

Complete the table.

	20	50	30	31	32	33	61	62	63	91	92	93	100
+7	27	57	37	38	39	40	68	69	70	98	99	100	107

2

Calculate the differences.

- a) $20 - 4 = 16$ b) $80 - 5 = 75$ c) $40 - 7 = 33$ d) $30 - 9 = 21$
 $30 - 6 = 24$ $50 - 9 = 41$ $30 - 8 = 22$ $90 - 3 = 87$
 $40 - 8 = 32$ $90 - 4 = 86$ $80 - 7 = 73$ $50 - 7 = 43$
 $70 - 2 = 68$ $70 - 8 = 62$ $50 - 5 = 45$ $40 - 9 = 31$

3

Fill in the sums.

- a) $4 + 2 = \boxed{6}$ $4 + 12 = \boxed{1} \boxed{6}$ $4 + 62 = \boxed{6} \boxed{6}$
b) $6 + 3 = \boxed{9}$ $6 + 23 = \boxed{2} \boxed{9}$ $6 + 53 = \boxed{5} \boxed{9}$
c) $1 + 7 = \boxed{8}$ $1 + 17 = \boxed{1} \boxed{8}$ $1 + 77 = \boxed{7} \boxed{8}$

4

Fill in the missing numbers.

- a) $55 - \boxed{5} = 50$ b) $10 + 50 + \boxed{8} = 68$
 $43 - \boxed{3} = 40$ $\boxed{4} \boxed{0} + 30 + 2 = 72$
 $\boxed{9} \boxed{7} - 7 = 90$ $20 + \boxed{6} \boxed{0} + 4 = 84$
 $\boxed{5} \boxed{2} - 2 = 50$ $\boxed{6} \boxed{0} + 20 + 6 = 86$

5

Use the number strip on page 39 to answer these questions. How many of the numbers from 0 to 100:

- a) are odd with 2 digits $\boxed{4} \boxed{5}$ b) have 2 odd digits $\boxed{2} \boxed{5}$
c) have only even digits $\boxed{2} \boxed{5}$ d) contain 0 $\boxed{1} \boxed{1}$
e) are less than 30 $\boxed{3} \boxed{0}$ f) are not less than 30? $\boxed{7} \boxed{1}$

1

Complete the table.

	30	10	40	90	50	49	48	47	46	80	79	77	76	100
-6	24	4	34	84	44	43	42	41	40	74	73	71	70	94

2

Write an addition and subtraction about each picture.

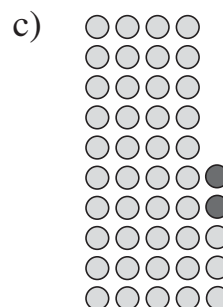
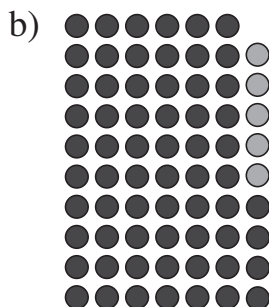
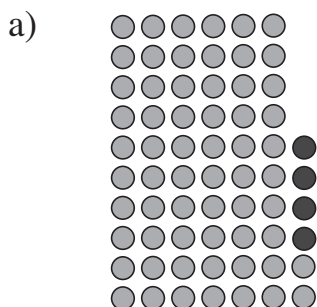

6 2 + 4 = 6 6

6 4 + 5 = 6 9

4 3 + 2 = 4 5

6 6 - 4 = 6 2

6 9 - 5 = 6 4

4 5 - 2 = 4 3

3

Colour in the coins to show how much money I have. Write it as an addition.

	Had	Was given	Now have	
a)				3 + 2 = 5
b)				1 3 + 2 = 1 5
c)				2 3 + 2 = 2 5
d)				3 + 1 2 = 1 5
e)				3 + 2 2 = 2 5
f)				1 3 + 1 2 = 2 5

4

Which is more? How many more? Write in the correct signs and numbers.

a) 42 < 4 46

b) 32 < 4 36

c) 87 > 3 84

51 < 8 59

60 > 7 53

50 > 15 35

1

Calculate:

- a) $16 - 2 = 14$ b) $27 - 4 = 23$ c) $59 - 1 = 58$ d) $88 - 8 = 80$
 $26 - 2 = 24$ $37 - 4 = 33$ $59 - 2 = 57$ $88 - 7 = 81$
 $36 - 2 = 34$ $47 - 4 = 43$ $59 - 3 = 56$ $88 - 6 = 82$
 $46 - 2 = 44$ $57 - 4 = 53$ $59 - 4 = 55$ $88 - 5 = 83$

2

Colour in the coins to show how much money I have. Write it as an equation.

	Had	Spent	Have left	
a)				$7 - 4 = 3$
b)				$17 - 4 = 13$
c)				$27 - 4 = 23$
d)				$17 - 14 = 3$
e)				$27 - 14 = 13$
f)				$27 - 24 = 3$

3

Follow the arrows and write the results in the cars.

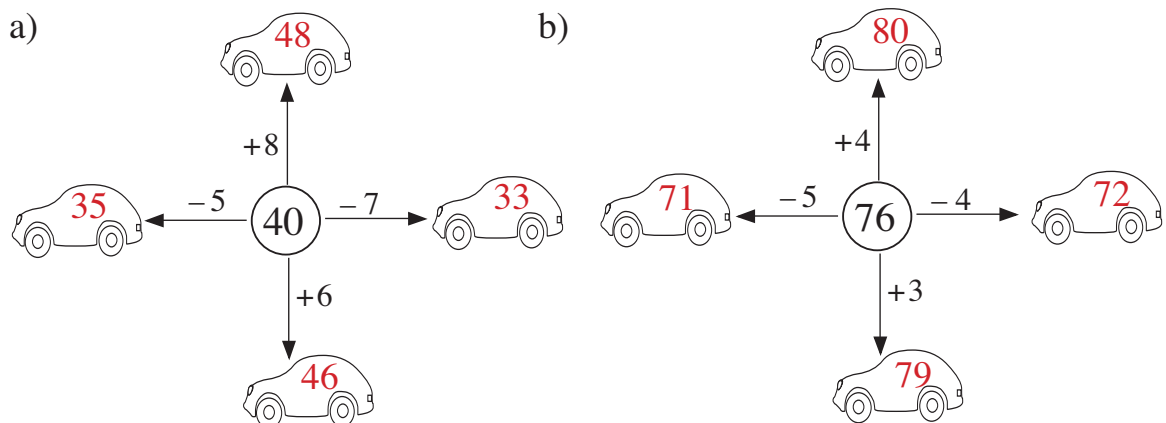

4

Write the correct sign and number on each arrow to show its meaning.

- a) $43 \xrightarrow{+4} 47 \xrightarrow{-7} 40 \xrightarrow{+10} 50 \xrightarrow{+8} 58 \xrightarrow{+10} 68$
 b) $90 \xrightarrow{+4} 94 \xrightarrow{-4} 90 \xrightarrow{-10} 80 \xrightarrow{+7} 87 \xrightarrow{-6} 81$

1

Fill in the missing numbers.

- a) $\boxed{4 \ 6} \xleftarrow{-4} 50 \xrightarrow{+4} \boxed{5 \ 4}$ b) $\boxed{7 \ 1} \xleftarrow{-9} 80 \xrightarrow{+9} \boxed{8 \ 9}$
- b) $\boxed{6 \ 2} \xleftarrow{-8} 70 \xrightarrow{+8} \boxed{7 \ 8}$ c) $\boxed{8 \ 3} \xleftarrow{-7} 90 \xrightarrow{+7} \boxed{9 \ 7}$

2

Study these jumps along the number line. Fill in the missing numbers.

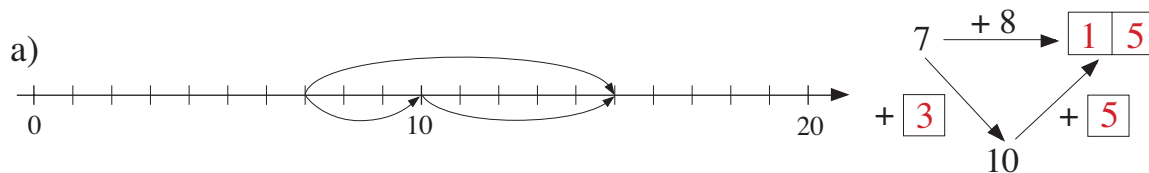
- a) 

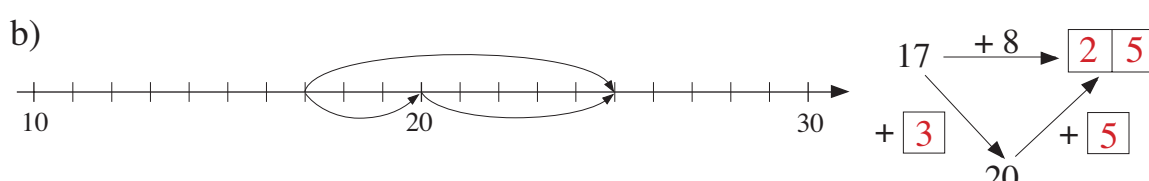
 b) 

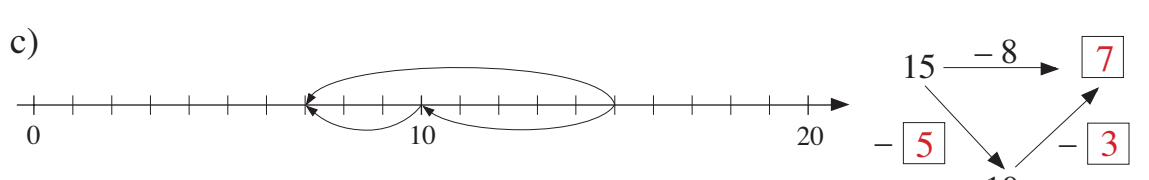
 c) 

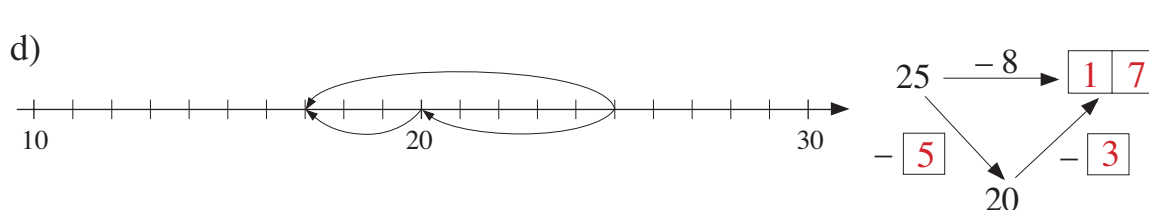
 d) 

3

Compare the sums.

- | | | |
|------------------|------------------|------------------|
| a) $27 + 1 = 28$ | b) $38 + 1 = 39$ | c) $49 + 1 = 50$ |
| $27 + 2 = 29$ | $38 + 2 = 40$ | $49 + 2 = 51$ |
| $27 + 3 = 30$ | $38 + 3 = 41$ | $49 + 3 = 52$ |
| $27 + 4 = 31$ | $38 + 4 = 42$ | $49 + 4 = 53$ |
| $27 + 5 = 32$ | $38 + 5 = 43$ | $49 + 5 = 54$ |
| $27 + 6 = 33$ | $38 + 6 = 44$ | $49 + 6 = 55$ |

4

Which numbers make this statement true?

$$54 < \triangle < 63 - 5$$

$$\triangle : 55, 56, 57 \dots$$

1 Complete the table.

+	17	27	37	47	57	67	77	87	97	
5	3	20	30	40	50	60	70	80	90	100
	2	22	32	42	52	62	72	82	92	102

2 Write additions and subtractions about the pictures.

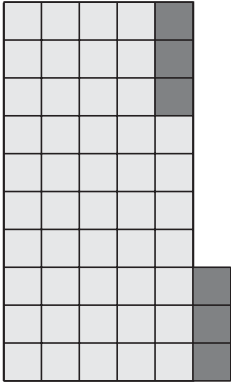
a)  $47 + 6 = 53$
 $47 + 3 + 3$
 $53 - 6 = 47$
 $53 - 3 - 3$

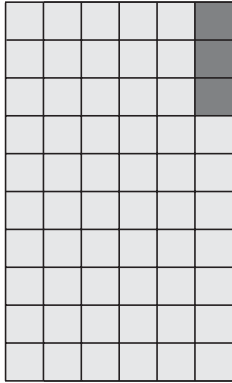
b)  $57 + 6 = 63$
 $57 + 3 + 3$
 $63 - 6 = 57$
 $63 - 3 - 3$

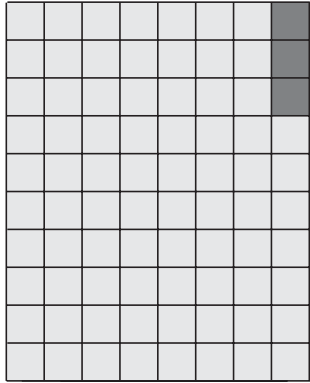
c)  $77 + 6 = 83$
 $77 + 3 + 3$
 $83 - 6 = 77$
 $83 - 3 - 3$

3 Replace the two operations with one operation. Fill in the missing numbers.

a) $19 \xrightarrow{+1} 20 \xrightarrow{+3} 23$
 $19 \xrightarrow{+4} 23$

b) $38 \xrightarrow{+2} 40 \xrightarrow{+4} 44$
 $38 \xrightarrow{+6} 44$

c) $57 \xrightarrow{+3} 60 \xrightarrow{+5} 65$
 $57 \xrightarrow{+8} 65$

d) $68 \xrightarrow{+2} 70 \xrightarrow{+5} 75$
 $68 \xrightarrow{+7} 75$

e) $83 \xrightarrow{-3} 80 \xrightarrow{-6} 74$
 $83 \xrightarrow{-9} 74$

f) $74 \xrightarrow{-4} 70 \xrightarrow{-2} 68$
 $74 \xrightarrow{-6} 68$

1

Fill in the table.

+	0	1	2	3	4	5	6	7	8	9	10	11	12	13	14	15	16	17	18	19	20
0	0	1	2	3	4	5	6	7	8	9	10	11	12	13	14	15	16	17	18	19	20
1	1	2	3	4	5	6	7	8	9	10	11	12	13	14	15	16	17	18	19	20	21
2	2	3	4	5	6	7	8	9	10	11	12	13	14	15	16	17	18	19	20	21	22
3	3	4	5	6	7	8	9	10	11	12	13	14	15	16	17	18	19	20	21	22	23
4	4	5	6	7	8	9	10	11	12	13	14	15	16	17	18	19	20	21	22	23	24
5	5	6	7	8	9	10	11	12	13	14	15	16	17	18	19	20	21	22	23	24	25
6	6	7	8	9	10	11	12	13	14	15	16	17	18	19	20	21	22	23	24	25	26
7	7	8	9	10	11	12	13	14	15	16	17	18	19	20	21	22	23	24	25	26	27
8	8	9	10	11	12	13	14	15	16	17	18	19	20	21	22	23	24	25	26	27	28
9	9	10	11	12	13	14	15	16	17	18	19	20	21	22	23	24	25	26	27	28	29
10	10	11	12	13	14	15	16	17	18	19	20	21	22	23	24	25	26	27	28	29	30

2

Fill in the missing numbers.

a) $8 \xrightarrow{+3} \begin{array}{|c|c|} \hline 1 & 1 \\ \hline \end{array}$
 $+ \begin{array}{|c|} \hline 2 \\ \hline \end{array} \searrow \quad \nearrow + \begin{array}{|c|} \hline 1 \\ \hline \end{array}$
 10

b) $5 \xrightarrow{+9} \begin{array}{|c|c|} \hline 1 & 4 \\ \hline \end{array}$
 $+ \begin{array}{|c|} \hline 5 \\ \hline \end{array} \searrow \quad \nearrow + \begin{array}{|c|} \hline 4 \\ \hline \end{array}$
 10

c) $7 \xrightarrow{+4} \begin{array}{|c|c|} \hline 1 & 1 \\ \hline \end{array}$
 $+ \begin{array}{|c|} \hline 3 \\ \hline \end{array} \searrow \quad \nearrow + \begin{array}{|c|} \hline 1 \\ \hline \end{array}$
 10

d) $18 \xrightarrow{+3} \begin{array}{|c|c|} \hline 2 & 1 \\ \hline \end{array}$
 $+ \begin{array}{|c|} \hline 2 \\ \hline \end{array} \searrow \quad \nearrow + \begin{array}{|c|} \hline 1 \\ \hline \end{array}$
 20

e) $15 \xrightarrow{+9} \begin{array}{|c|c|} \hline 2 & 4 \\ \hline \end{array}$
 $+ \begin{array}{|c|} \hline 5 \\ \hline \end{array} \searrow \quad \nearrow + \begin{array}{|c|} \hline 4 \\ \hline \end{array}$
 20

f) $17 \xrightarrow{+4} \begin{array}{|c|c|} \hline 2 & 1 \\ \hline \end{array}$
 $+ \begin{array}{|c|} \hline 3 \\ \hline \end{array} \searrow \quad \nearrow + \begin{array}{|c|} \hline 1 \\ \hline \end{array}$
 20

g) $12 \xrightarrow{-3} \begin{array}{|c|c|} \hline & 9 \\ \hline \end{array}$
 $- \begin{array}{|c|} \hline 2 \\ \hline \end{array} \searrow \quad \nearrow - \begin{array}{|c|} \hline 1 \\ \hline \end{array}$
 10

h) $14 \xrightarrow{-6} \begin{array}{|c|c|} \hline & 8 \\ \hline \end{array}$
 $- \begin{array}{|c|} \hline 4 \\ \hline \end{array} \searrow \quad \nearrow - \begin{array}{|c|} \hline 2 \\ \hline \end{array}$
 10

i) $11 \xrightarrow{-5} \begin{array}{|c|c|} \hline & 6 \\ \hline \end{array}$
 $- \begin{array}{|c|} \hline 1 \\ \hline \end{array} \searrow \quad \nearrow - \begin{array}{|c|} \hline 4 \\ \hline \end{array}$
 10

j) $22 \xrightarrow{-3} \begin{array}{|c|c|} \hline 1 & 9 \\ \hline \end{array}$
 $- \begin{array}{|c|} \hline 2 \\ \hline \end{array} \searrow \quad \nearrow - \begin{array}{|c|} \hline 1 \\ \hline \end{array}$
 20

k) $24 \xrightarrow{-6} \begin{array}{|c|c|} \hline 1 & 8 \\ \hline \end{array}$
 $- \begin{array}{|c|} \hline 4 \\ \hline \end{array} \searrow \quad \nearrow - \begin{array}{|c|} \hline 2 \\ \hline \end{array}$
 20

l) $21 \xrightarrow{-5} \begin{array}{|c|c|} \hline 1 & 6 \\ \hline \end{array}$
 $- \begin{array}{|c|} \hline 1 \\ \hline \end{array} \searrow \quad \nearrow - \begin{array}{|c|} \hline 4 \\ \hline \end{array}$
 20

3

Complete the subtractions.

- a) $42 - 6 = 42 - 2 - 4 = \begin{array}{|c|c|} \hline 3 & 6 \\ \hline \end{array}$
- b) $55 - 7 = 55 - 5 - 2 = 48$
- c) $54 - 5 = 54 - 4 - 1 = 49$
- d) $72 - 8 = 72 - 2 - 6 = 64$

1

Complete the table.

E.g:

–	32	45	38	56	73	84	21	97	69
8	30	40	30	50	70	80	20	90	61
	24	37	30	48	65	76	13	89	61

2

Complete the table.

+	20	21	22	23	24	25	26	27	28	29
30	50	51	52	53	54	55	56	57	58	59
31	51	52	53	54	55	56	57	58	59	60
32	52	53	54	55	56	57	58	59	60	61
33	53	54	55	56	57	58	59	60	61	62
34	54	55	56	57	58	59	60	61	62	63
35	55	56	57	58	59	60	61	62	63	64
36	56	57	58	59	60	61	62	63	64	65
37	57	58	59	60	61	62	63	64	65	66
38	58	59	60	61	62	63	64	65	66	67
39	59	60	61	62	63	64	65	66	67	68

3

Join up the equal numbers

4

Complete the table. Write down the rule in different ways.

<i>a</i>	6	11	0	20	31	7	27	37	9	19	29	8	28	36	46
<i>b</i>	10	15	4	24	35	11	31	41	13	23	33	12	32	40	50

Rule: $a + 4 = b$, $b - 4 = a$, $b - a = 4$

1

Fill in the missing numbers.

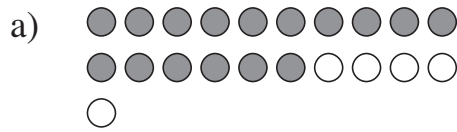

$$16 + \boxed{5} = \boxed{21}$$

$$16 + \boxed{4} + \boxed{1}$$

$$21 - \boxed{5} = \boxed{16}$$

$$21 - \boxed{1} - \boxed{4}$$

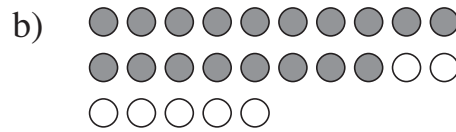

$$28 + \boxed{7} = \boxed{35}$$

$$28 + \boxed{2} + \boxed{5}$$

$$35 - \boxed{7} = \boxed{28}$$

$$35 - \boxed{5} - \boxed{2}$$

2

Fill in the missing numbers.

- a) $34 + \boxed{4} = 38$ $56 + \boxed{3} = 59$ $41 + \boxed{6} = 47$
- b) $86 - \boxed{4} = 82$ $91 - \boxed{1} = 90$ $75 - \boxed{2} = 73$
- c) $\boxed{61} + 8 = 69$ $\boxed{97} + 2 = 99$ $\boxed{72} + 5 = 77$
- d) $\boxed{66} - 4 = 62$ $\boxed{59} - 3 = 56$ $\boxed{87} - 2 = 85$

3

Fill in the amounts and write equations about the pictures.

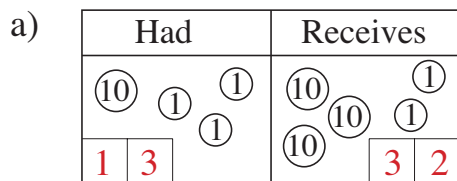

$$\boxed{13} + \boxed{32} = \boxed{45}$$

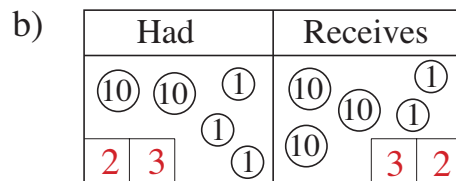

$$\boxed{23} + \boxed{32} = \boxed{55}$$

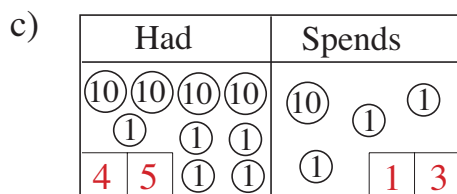

$$\boxed{45} - \boxed{13} = \boxed{32}$$

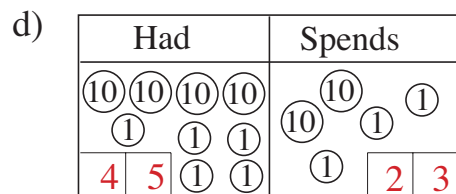

$$\boxed{45} - \boxed{23} = \boxed{22}$$

4

Join up the equal numbers.

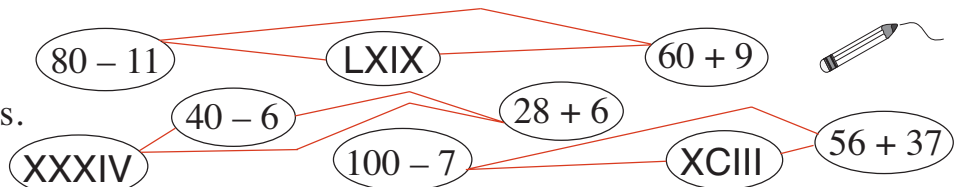

1

Follow the pattern. Add the tens first, then the units to the number.

a) $23 \xrightarrow{+30} 53 \xrightarrow{+6} 59$
 + 36

b) $46 \xrightarrow{+40} 86 \xrightarrow{+2} 88$
 + 42

c) $35 \xrightarrow{+20} 55 \xrightarrow{+3} 58$
 + 23

d) $53 \xrightarrow{+30} 83 \xrightarrow{+8} 91$
 + 38

e) $78 \xrightarrow{+10} 88 \xrightarrow{+6} 94$
 + 16

f) $67 \xrightarrow{+20} 87 \xrightarrow{+9} 96$
 + 29

2

Write additions and subtractions about the pictures.

a)

$32 + 25 = 57$

$25 + 32 = 57$

$57 - 32 = 25$

$57 - 25 = 32$

b)

$44 + 52 = 96$

$52 + 44 = 96$

$96 - 44 = 52$

$96 - 52 = 44$

c)

$26 + 62 = 88$

$62 + 26 = 88$

$88 - 62 = 26$

$88 - 26 = 62$

3

Peter and his Dad were digging up potatoes. Peter's Dad dug up 24 more potatoes than Peter did. Complete the table and the statements.

P	33	55	48	69	27	56	29	38	46	66	21	37
D	57	79	72	93	51	80	53	62	70	90	45	61

. D. $24 > P$. . . D = P. + 24. P = D. - 24. 24 = D. - P.

4

Ann has 56 buttons and Barbara has 27 buttons.

How many do they have altogether?

$56 + 27 = 83$

1

Fill in the missing numbers.

$$a) \quad 18 \xrightarrow{+12} \boxed{30} \xrightarrow{+36} \boxed{66} \xrightarrow{+17} \boxed{83} \xrightarrow{+9} \boxed{92} \xrightarrow{-12} \boxed{80}$$

$$b) \quad 22 \xrightarrow{+14} \boxed{36} \xrightarrow{+27} \boxed{63} \xrightarrow{+19} \boxed{82} \xrightarrow{-34} \boxed{48} \xrightarrow{-48} \boxed{0}$$

2

List the possible solutions and mark them on the number line.

$$a) \quad 62 + 7 > \triangle > 65 - 4$$

$$\triangle : \quad 62, 63, 64, 65, 66, 67, 68$$

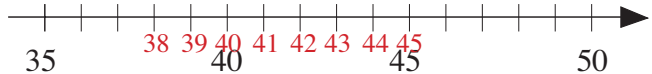
$$b) \quad 48 - 8 < \bullet + 3 < 42 + 7$$

$$\bullet : \quad 38, 39, 40, 41, 42, 43, 44, 45$$

3

Practise subtraction.

a) $93 - 51 = 42$	b) $85 - 62 = 23$	c) $86 - 54 = 32$
$76 - 23 = 53$	$97 - 56 = 41$	$93 - 62 = 31$
$65 - 41 = 24$	$68 - 17 = 51$	$52 - 31 = 21$
$87 - 54 = 33$	$54 - 32 = 22$	$78 - 13 = 65$
$52 - 31 = 21$	$87 - 65 = 22$	$55 - 44 = 11$
$47 - 26 = 21$	$96 - 74 = 22$	$69 - 45 = 24$

4

Calculate:

a) $65 + 24 = 89$	b) $74 - 13 = 61$	c) $12 + 15 = 27$
$65 + 35 = 100$	$74 - 54 = 20$	$23 + 15 = 38$
$65 + 16 = 81$	$74 - 25 = 49$	$34 + 15 = 49$
$65 + 27 = 92$	$74 - 36 = 38$	$45 + 15 = 60$
$65 + 38 = 103$	$74 - 47 = 27$	$51 - 15 = 36$
$65 + 19 = 84$	$74 - 68 = 6$	$62 - 15 = 47$
$65 + 40 = 105$	$74 - 19 = 55$	$73 - 15 = 58$

1

Draw the coins I have left in my purse. Fill in the missing numbers.

Have left

<i>Had</i>	+	20	2	0	=	a)	20	20	10	5	5	5		
20	+	5	2	7	=	b)	20	10	5	5	2	4	2	
10	+	20	5	2	=	c)	20	20	10	5	5	2	6	2
5	-	20	2	0	=	d)	10	5	1	5				
3	-	5	2	7	=	e)	20	2	2	2	2	2	2	8
5	-	20	5	2	=	f)	2	2	2	2	2	8		

2

Do the calculations and fill in the missing numbers.

- | | |
|---|---|
| a) $48 + 22 <^8$ 7 8 | b) $87 - 26 <^{14}$ 7 5 |
| c) 3 4 $<^9$ $90 - 47$ | d) 5 8 $<^{25}$ $48 + 35$ |
| e) $52 + 19 <^{13}$ 8 4 | f) $77 - 34 <^{16}$ 5 9 |

3

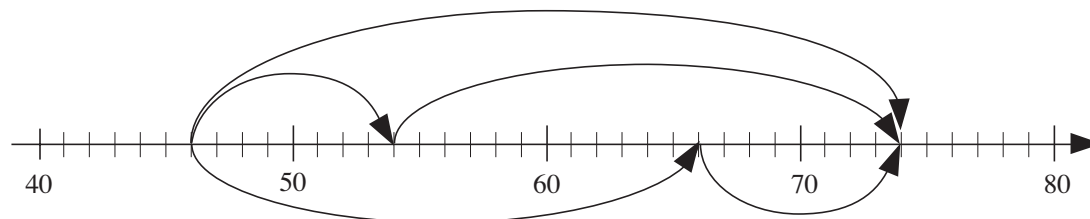

Study the jumps along the number line.

Fill in the missing numbers.

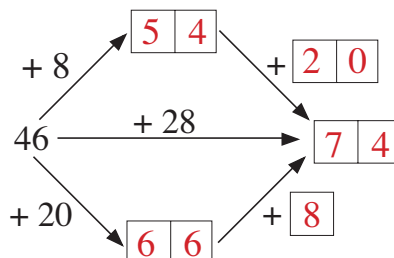

4

Kate has 37 fewer books than Suzie has.

Complete the table and the equations.

S	84	73	58	67	90	100					
K	47	36	21	30	53	63	18	39	23	42	55

$K = S - 37$
 $S = K + 37$
 $37 = S - K$

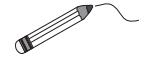
**1**

Join up each measurement to a suitable length.

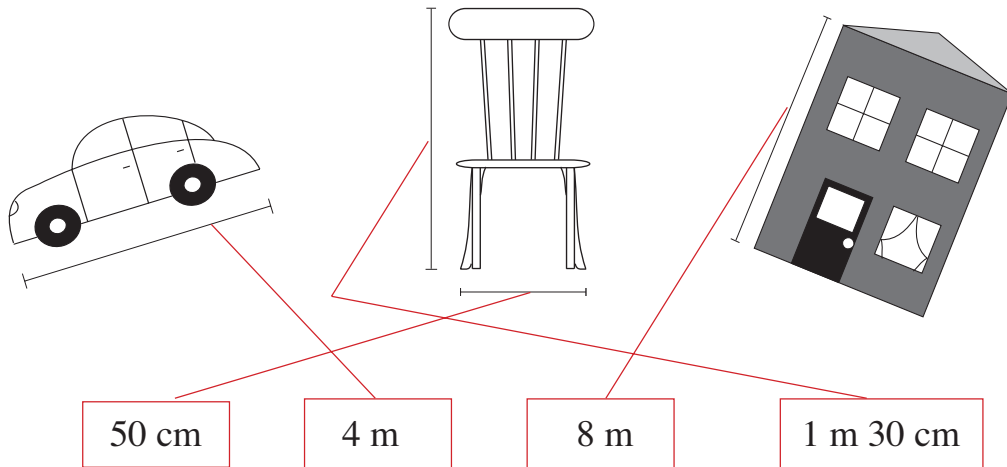
**2**

The length of a yellow strip is 5 cm.



What is the total length of:

a) 2 yellow strips

$$\boxed{5} + \boxed{5} = \boxed{10} \text{ cm}$$

$$\boxed{2} \text{ times } 5 \text{ cm} = \boxed{10} \text{ cm}$$

b) 4 yellow strips

$$\boxed{5} + \boxed{5} + \boxed{5} + \boxed{5} = \boxed{20} \text{ cm}$$

$$\boxed{4} \text{ times } 5 \text{ cm} = \boxed{20} \text{ cm}$$

c) 8 yellow strips?

$$\boxed{5} + \boxed{5} + \boxed{5} + \boxed{5} + \boxed{5} + \boxed{5} + \boxed{5} + \boxed{5} = \boxed{40} \text{ cm}$$

$$\boxed{8} \text{ times } 5 \text{ cm} = \boxed{40} \text{ cm}$$

3**1 metre**

$$40 \text{ cm} + \boxed{60 \text{ cm}}$$

$$80 \text{ cm} + \boxed{20 \text{ cm}}$$

$$\boxed{75 \text{ cm}} + 25 \text{ cm}$$

$$\boxed{39 \text{ cm}} + 61 \text{ cm}$$

$$99 \text{ cm} + \boxed{1 \text{ cm}}$$

Fill in the missing numbers and units.

50 cm

$$20 \text{ cm} + \boxed{30 \text{ cm}}$$

$$84 \text{ cm} - \boxed{34 \text{ cm}}$$

$$\boxed{8 \text{ cm}} + 42 \text{ cm}$$

$$\boxed{83 \text{ cm}} - 33 \text{ cm}$$

$$1 \text{ cm} + \boxed{49 \text{ cm}}$$

1

Do the subtractions. Check them with an addition and a subtraction.
Follow the pattern.

- a) $35 - 12 = 23$ Checks: $35 - 23 = 12$ $23 + 12 = 35$
- b) $47 - 23 = 24$ $47 - 24 = 23$... $24 + 23 = 47$...
- c) $86 - 38 = 48$ $86 - 48 = 38$... $48 + 38 = 86$...
- d) $78 - 29 = 49$ $78 - 49 = 29$... $49 + 29 = 78$...
- e) $93 - 77 = 16$ $93 - 16 = 77$... $16 + 77 = 93$...

2

Fill in the missing numbers. What is the total length of 5 strips if:

- a) each strip is 4 cm long 

$$\boxed{4} + \boxed{4} + \boxed{4} + \boxed{4} + \boxed{4} = \boxed{20} \text{ cm}$$

$$\boxed{5} \text{ times } \boxed{4} \text{ cm} = \boxed{20} \text{ cm}$$

- b) each strip is 8 cm long? 

$$\boxed{8} + \boxed{8} + \boxed{8} + \boxed{8} + \boxed{8} = \boxed{40} \text{ cm}$$

$$\boxed{5} \text{ times } \boxed{8} \text{ cm} = \boxed{40} \text{ cm}$$

3

- a) Ant and Ladybird are 10 cm away from each other.
Mark where Ladybird should be on the line and draw her.



- b) They start walking towards each other and meet half-way under a mushroom. Mark where the mushroom should be and draw it.
- c) What distance did they walk? Ant: $\boxed{5}$ cm Ladybird: $\boxed{5}$ cm

4

Mark where to cut a 10 cm piece of ribbon so that one piece is 2 cm longer than the other.

Write the length
inside each piece.



1



Measure each child in your class. Keep a tally of the heights in this table.

$1\text{ m} < \text{height} \leq 1\text{ m } 10\text{ cm}$	
$1\text{ m } 10\text{ cm} < \text{height} \leq 1\text{ m } 20\text{ cm}$	
$1\text{ m } 20\text{ cm} < \text{height} \leq 1\text{ m } 30\text{ cm}$	
$1\text{ m } 30\text{ cm} < \text{height} \leq 1\text{ m } 40\text{ cm}$	
$1\text{ m } 40\text{ cm} < \text{height} \leq 1\text{ m } 50\text{ cm}$	

- The most common height group is:
- The least common height group is:
- The height group of the tallest children is:
- The height group of the shortest children is:

2

Measure and mark these lengths on the lines.

- 7 cm 
- 11 cm 
- 8 cm 

3

Fill in the missing numbers.

$$43\text{ cm} + 29\text{ cm} <_{12\text{ cm}} \boxed{8} \boxed{4}\text{ cm} \quad 59\text{ cm} + 17\text{ cm} >_{25\text{ cm}} \boxed{5} \boxed{1}\text{ cm}$$

$$94\text{ cm} - 52\text{ cm} <_{16\text{ cm}} \boxed{5} \boxed{8}\text{ cm} \quad \boxed{1} \boxed{3}\text{ cm} <_{34\text{ cm}} 86\text{ cm} - 39\text{ cm}$$

4

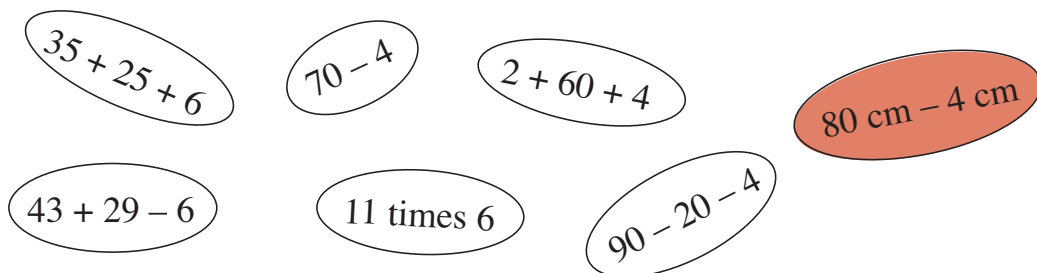

$35 + 25 + 6$ $70 - 4$ $2 + 60 + 4$ $80\text{ cm} - 4\text{ cm}$
 $43 + 29 - 6$ $11\text{ times } 6$ $90 - 20 - 4$

Colour in the one which you think is the odd one out. Why?

This calculation does not equal 66 and is a quantity of length, not a number.

1 Continue the sequences. Complete the rules.

- a) 0, 4, 8,
 2, 6, 10,
 3, 7, 11,

The sequences **increase** by

- b) 40, 36, 32,
 39, 35, 31,
 37, 33, 29,

The sequences **decrease** by



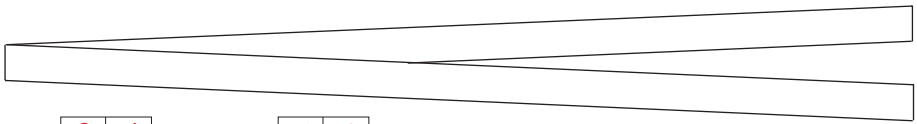

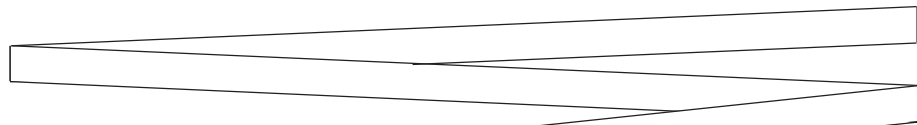
2 Measure each strip and calculate the total length of two such strips.

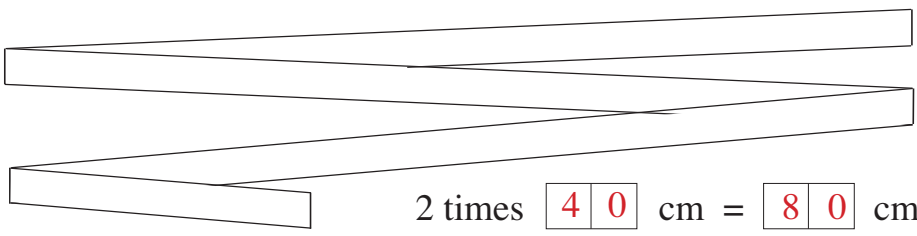
a) 
 2 times cm = cm

b) 
 2 times cm = cm

c) 
 2 times cm = cm

3 How long is each line segment?
 Estimate first, then measure.

- a 
- b 
- c 
- d 
- e 

	Estimate	Measurement	Difference
a		1 cm	
b		4 cm	
c		3 cm	
d		6 cm	
e		2 cm	

1

- a) Colour blue the quadrilaterals which are **rectangles**.
 b) Circle in red the rectangles which are **squares**.

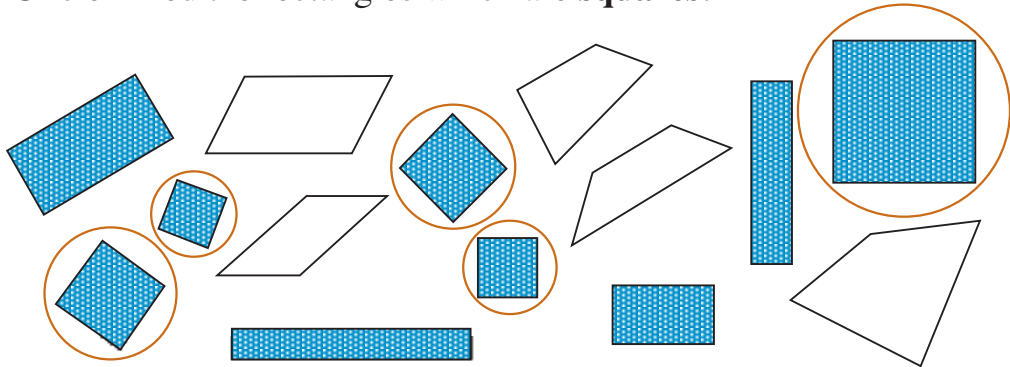

2

Rabbit is sitting at one side of a rectangular field.

- a) Which animal is sitting on the **opposite** side of the field?

..... **Frog**

- b) Which animals are sitting on the sides of the field **adjacent** to Rabbit's side?

..... **Hedgehog** and **Bird**

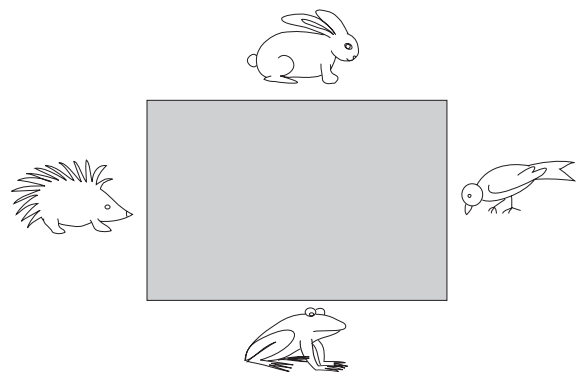

3

- a) Colour yellow the quadrilaterals which can be folded in half so that the two halves cover each other exactly.

- b) Draw in the **fold lines**. Try to find different fold lines.

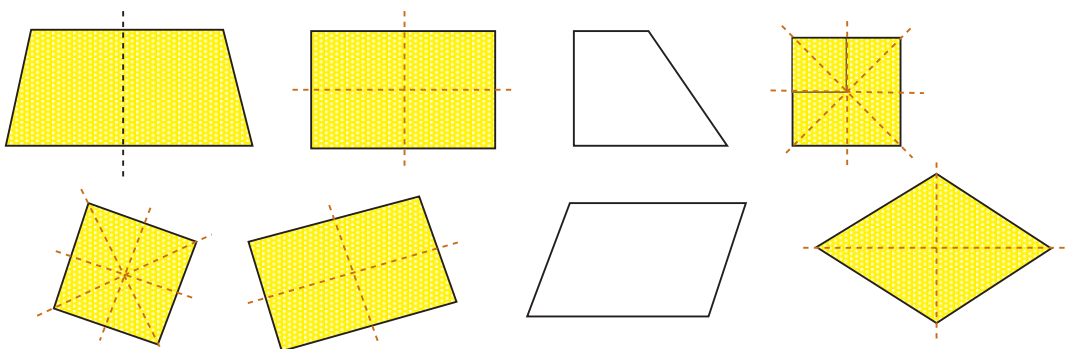

4

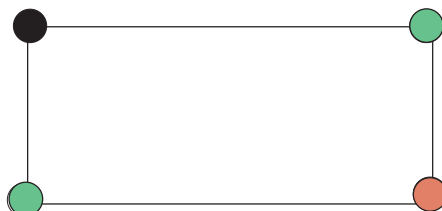

- a) Colour red the vertex **opposite** the black one.

- b) Colour green the vertices **adjacent** to the black one.



1

Find the rule and complete the table. Write the rule in different ways.

	12	33	41	18	45	36	27	48	32	11	44	43	10	E.g. 12
	16	29	24	27	19	36	12	11	32	25	18	38	90	10
	28	62	65	45	64	72	39	59	64	36	62	81	100	22

 =  + 
  =  - 
  =  - 

2

Continue the sequences in 2 different ways. For example:

a) 



b) 



3

Draw over the equal sides of each quadrilateral in the same colour.



4

Draw in the two missing sides of each quadrilateral to form a rectangle.

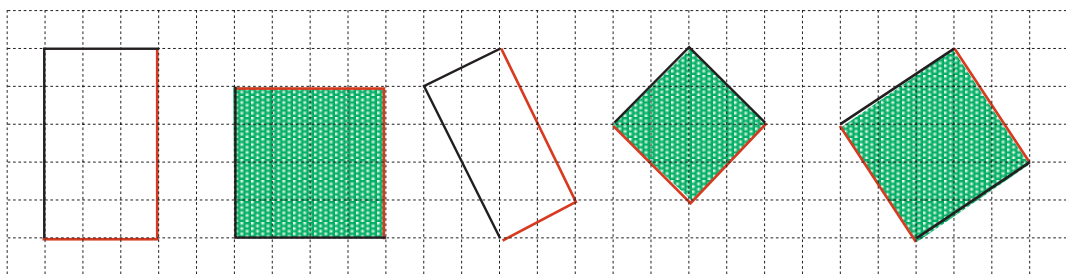

Colour green the rectangles which are **squares**.

5

How many sides has: a pentagon 5 a hexagon? 6

1

Draw over the equal sides of the rectangles in the same colour.

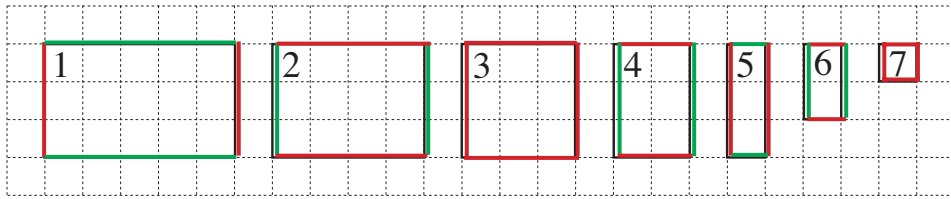

Write down the numbers of those rectangles which are also squares. **3 and 7**

2

Complete each drawing to make a rectangle.

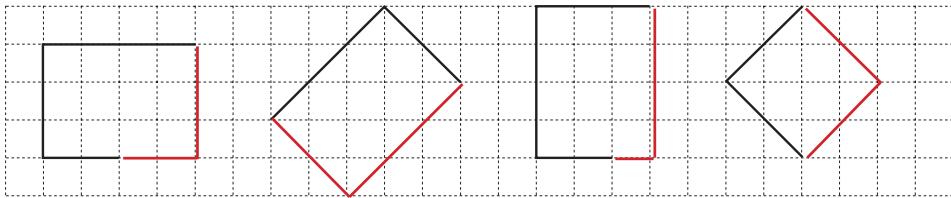

3

How many rectangles can you see on this figure? **9 rectangles**
 Draw each of them again on the grid. Colour the squares blue.

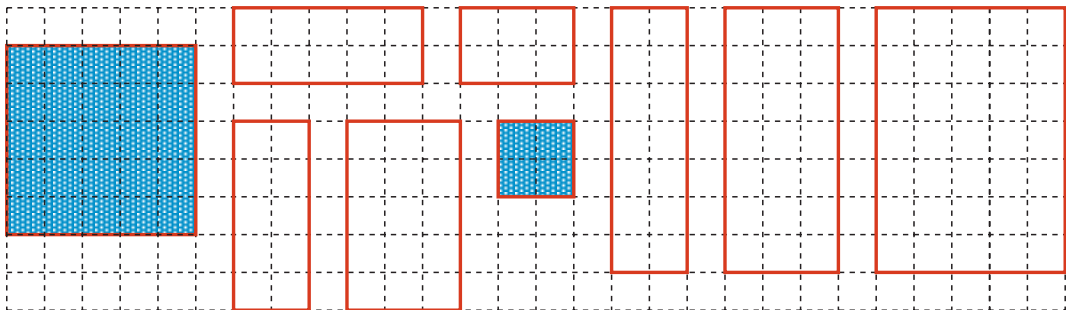

4

How many unit squares can you cover each shape with? 1 unit square

a)	b)	c)	d)
<input type="text" value="5"/> unit squares	<input type="text" value="8"/> unit squares	<input type="text" value="1"/> <input type="text" value="1"/> unit squares	<input type="text" value="8"/> unit squares

1 List the numbers which make the statements true.

a) $40 + 33 < \triangle < 100 - 23$ $\triangle : \dots 74, 75, 76 \dots$

b) $87 - 4 < 80 + \bigcirc < 92 - 5$ $\bigcirc : \dots 4, 5, 6 \dots$

2 Find different ways to colour half of the rectangles.

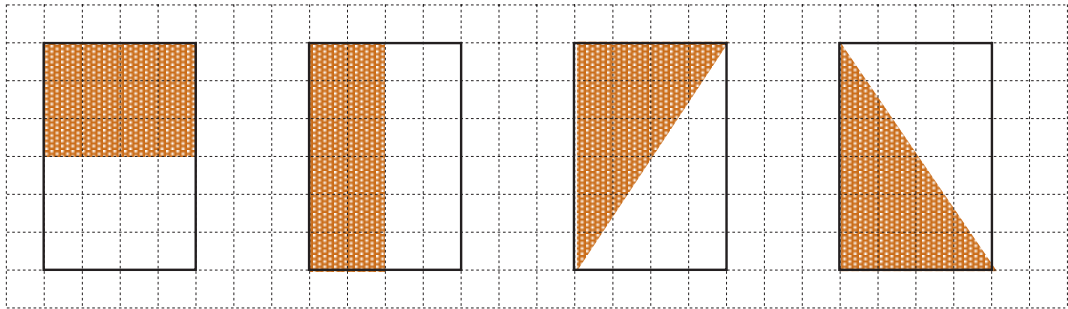

3 Two rectangles were cut into 2 pieces and these triangles were made from them. Draw the original rectangles.

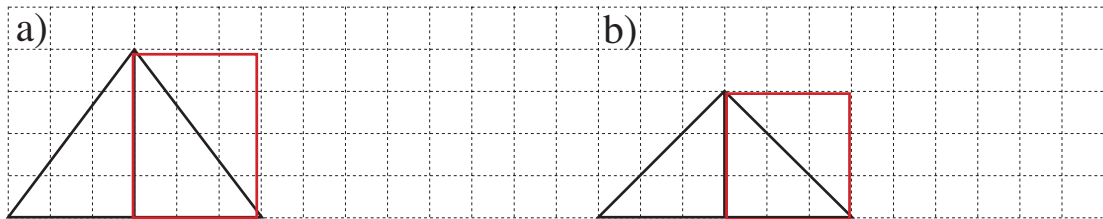

4 The two triangles were made from the rectangle which had been cut into two pieces. Continue the colouring.

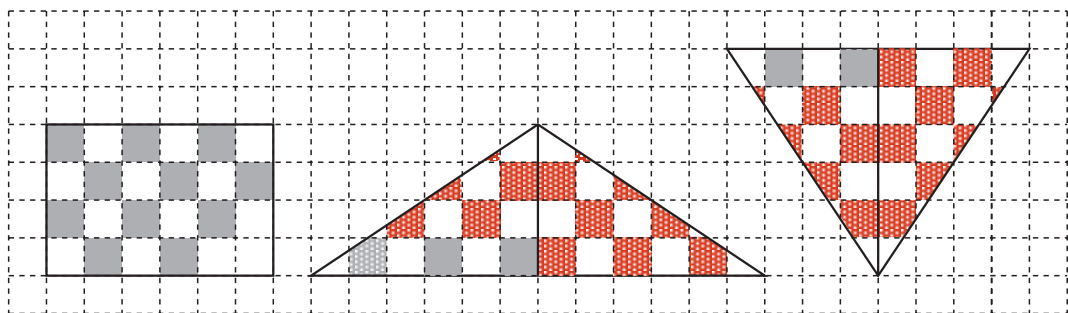

5 An **octagon** has 8 sides.
Draw an octagon.

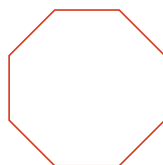

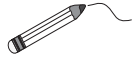

1 Join up the equal numbers.

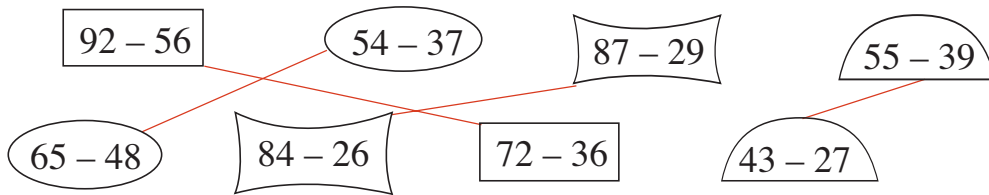

What do you notice? **The shapes are the same for the numbers which are equal.**

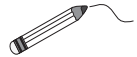

2 Draw arrows towards the container which holds more water.

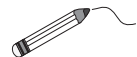
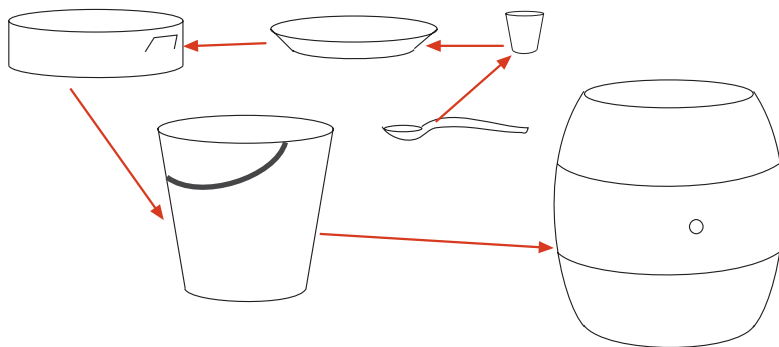

3 Join up each measure of capacity to a suitable container.

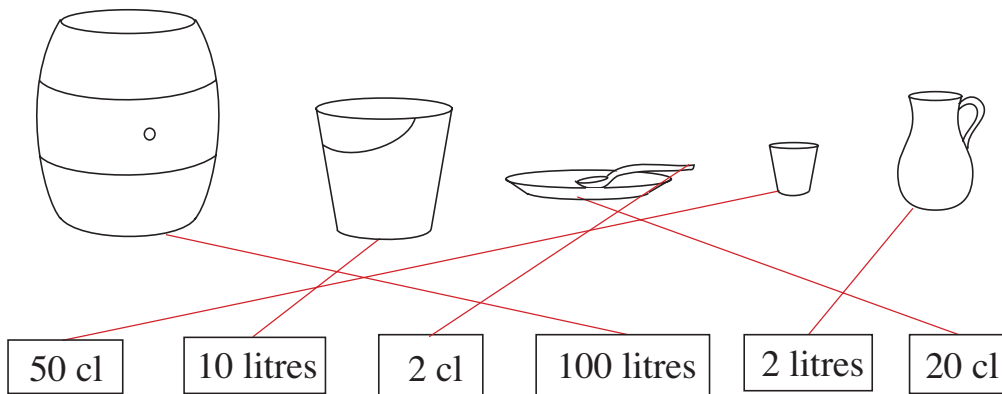

4 Fill in the missing numbers and standard units.

- | | |
|--|--|
| a) $30 \text{ cl} + \boxed{55 \text{ cl}} = 85 \text{ cl}$ | b) $1 \text{ litre} - \boxed{72 \text{ cl}} = 28 \text{ cl}$ |
| $\boxed{30 \text{ cl}} + 70 \text{ cl} = 1 \text{ litre}$ | $\boxed{1 \text{ litre}} - 49 \text{ cl} = 51 \text{ cl}$ |
| $42 \text{ cl} + \boxed{42 \text{ cl}} = 84 \text{ cl}$ | $\boxed{1 \text{ litre}} - 51 \text{ cl} = 49 \text{ cl}$ |
| $63 \text{ cl} + \boxed{28 \text{ cl}} = 91 \text{ cl}$ | $1 \text{ litre} - \boxed{100 \text{ cl}} = 0 \text{ cl}$ |

1

If the statement is correct, put a ✓ in the box. If it is incorrect, put a ✗ in the box and correct it.

a) $26 \text{ cl} + 28 \text{ cl} > 62 \text{ cl}$ ✗
 $26 \text{ cl} + 28 \text{ cl} < 62 \text{ cl}$

b) $38 \text{ cm} + 51 \text{ cm} > 76 \text{ cm}$ ✓

$73 \text{ m} - 24 \text{ m} = 49 \text{ m}$ ✓

$64 \text{ kg} - 37 \text{ kg} < 18 \text{ kg}$ ✗
 $64 \text{ kg} - 37 \text{ kg} > 18 \text{ kg}$

2

The measuring jugs can each hold 1 litre of water at the most. How much water is in each one? Fill in the missing numbers.

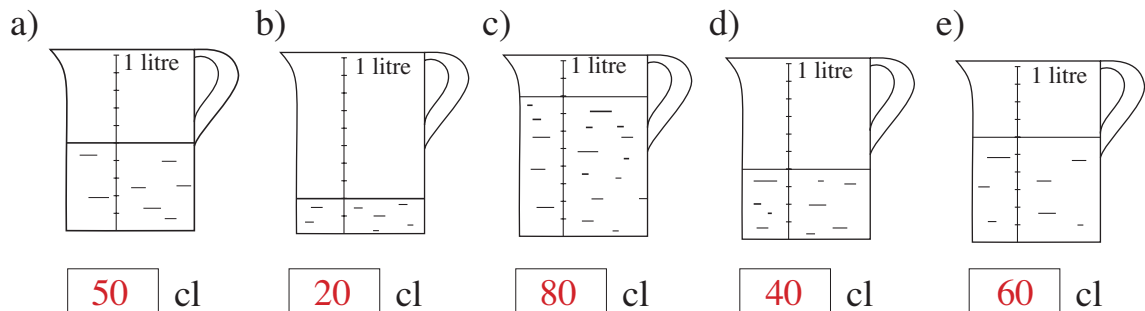
**3**

How many 40 cl glasses can be filled from a jug holding 1 litre 60 cl of lemonade?

$1 \text{ litre } 60 \text{ cl} = 40 \text{ cl} + 40 \text{ cl} + 40 \text{ cl} + 40 \text{ cl}$

Answer: glasses

4

Write an addition or subtraction for each problem

a) There are 4 litres 60 cl of water in a bucket.

We pour in another 70 cl. $4 \text{ litres } 60 \text{ cl} + 70 \text{ cl} = 5 \text{ litres } 30 \text{ cl}$

How much water is in the bucket now? Answer:

b) There are 3 and a half litres of orange juice in a jug.

We pour out 90 cl. $3 \text{ litres } 50 \text{ cl} - 90 \text{ cl} = 2 \text{ litres } 60 \text{ cl}$

How much orange juice is left in the jug? Answer:

c) How many half litre bottles $1 \text{ litre} = 2 \text{ half litres.}$

can be filled from 4 litres $4 \text{ litres} = 2 + 2 + 2 + 2 = 4 \text{ times } 2$
of milk? $= 8 \text{ half litres}$

Answer: bottles

1

When making up a cough mixture, 3 cl of medicine should be mixed with 1 cup of syrup. How much medicine and cups of syrup are needed to make up more cough mixture?



Complete the table.

Number of cups	0	3	5	7	4	1	8	10	2	6	9
Medicine (cl)	0	9	15	21	12	3	24	30	6	18	27

2

Fill in the missing units.

- a) $30 \text{ cl} + 2 \text{ cl} = 32 \text{ .cl.}$...
- b) $2 \text{ litres } 80 \text{ cl} + 1 \text{ litre } 20 \text{ cl} = 4 \text{ .litres}$
- c) $28 \text{ litres} + 12 \text{ litres} = 40 \text{ .litres}$
- d) $3 \text{ litres } 90 \text{ cl} - 90 \text{ cl} = 3 \text{ .litres}$
- e) $5 \text{ litres} - 100 \text{ cl} = 4 \text{ .litres}$
- f) $7 \text{ litres } 30 \text{ cl} - 2 \text{ litres} = 5 \text{ .litres}$ 30 .cl. ...

3

Join up the quantities to the correct statement.

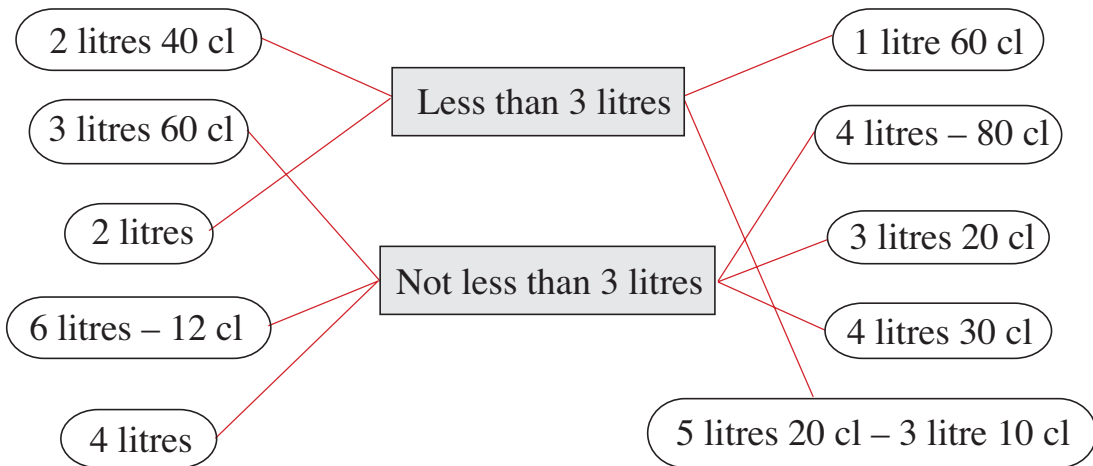
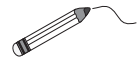

4

Fill in the missing numbers and units.

- a) $1 \text{ litre} = \boxed{100} \text{ cl}$ b) 1 .metre = 100 cm
- $50 \text{ cl} = \text{half a .litre}$ Half a metre = $\boxed{5} \boxed{0} \text{ .cm}$

1

Fill in the missing numbers.

a) $26 + 7 = 41 - \boxed{} \boxed{8}$

b) $7 + 57 = \boxed{7} \boxed{2} - 8$

$\boxed{4} \boxed{9} + 5 = 63 - 9$

$\boxed{} \boxed{7} + 76 = 9 + 74$

$74 - \boxed{} \boxed{9} = 58 + 7$

$92 - \boxed{} \boxed{8} = 75 + 9$

$\boxed{6} \boxed{1} - 8 = 45 + 8$

$6 + 56 = \boxed{7} \boxed{0} - 8$

2

Write down a quantity (number and standard unit) which will make the statements true and false.

a) $30 \text{ cl} + \boxed{?} < 39 \text{ cl}$

b) $79 \text{ m} - \boxed{?} > 72 \text{ m}$

E.g:

E.g:

True: **2 cl**

True: **3 m**

False: **10 cl**

False: **9 m**

3

Last week, Jack drank 3 litres 40 cl of lemonade and 2 litres 60 cl of milk. How much lemonade and milk did Jack drink last week altogether?

3 litres 40 cl + 2 litres 60 cl = 6 litres

Answer: **6 litres**

4

Join up the quantities in the centre to the equal ones at the sides. 

