

Spent (p)					
Had left (p)					

LP 111/2

a)

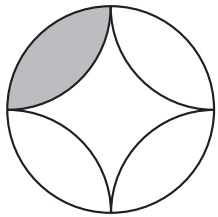

b)

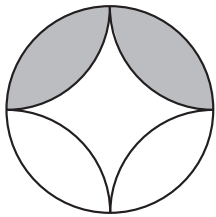

c)

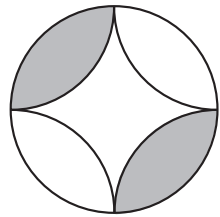

d)

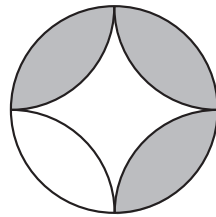

e)

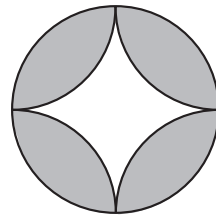

f)

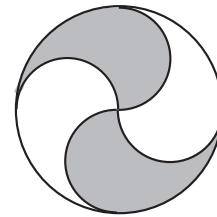

g)

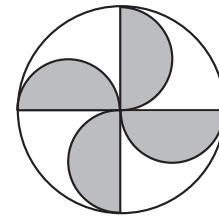

h)

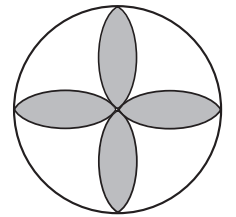

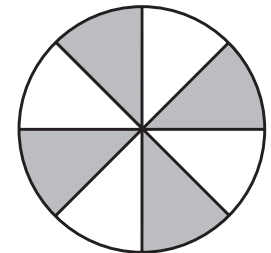
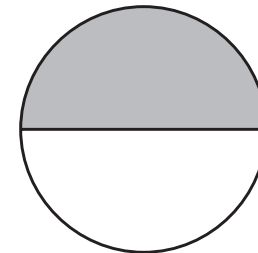
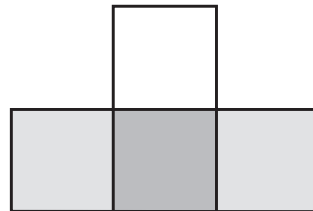
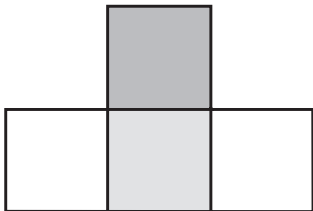
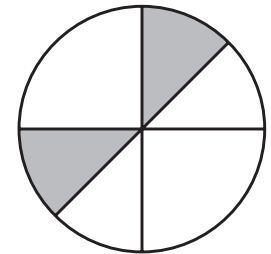
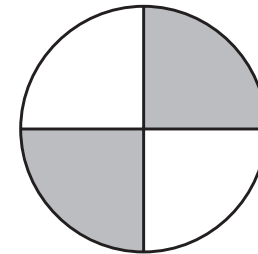
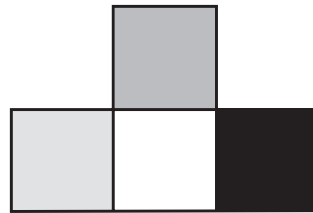
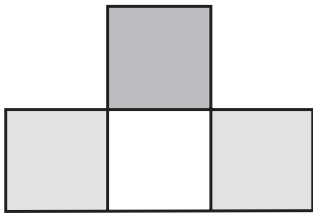
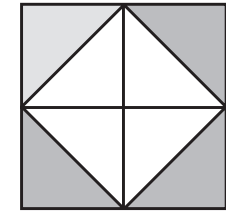
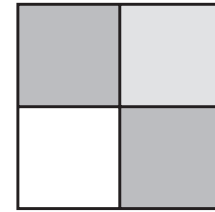
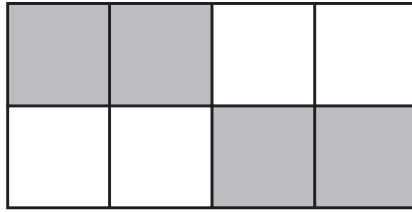
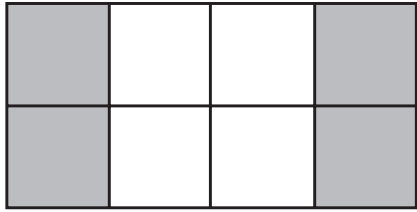
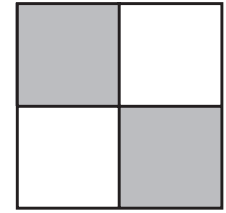
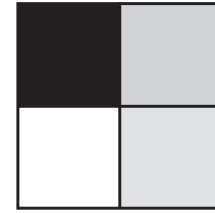
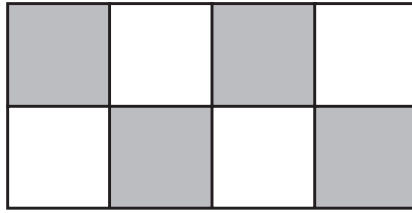
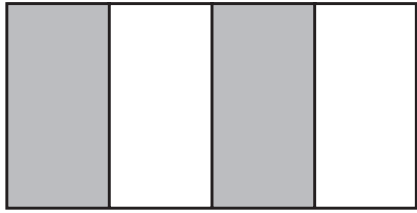

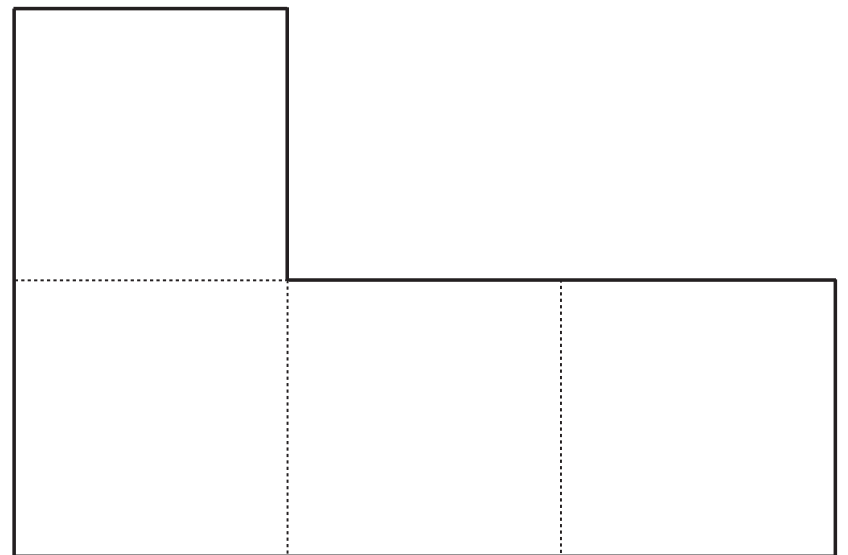
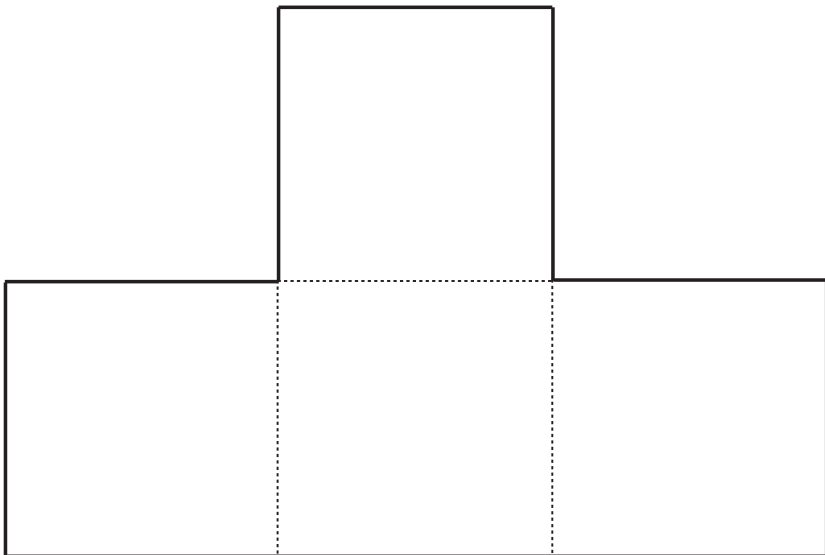
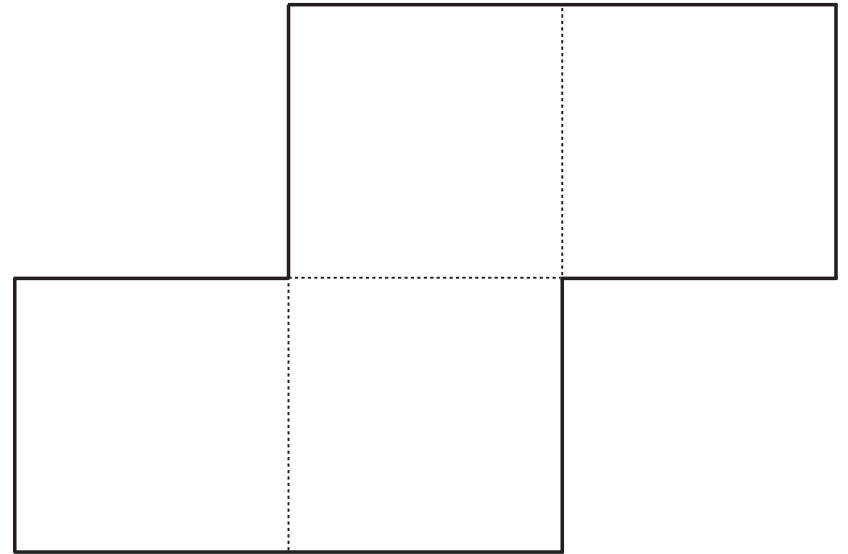
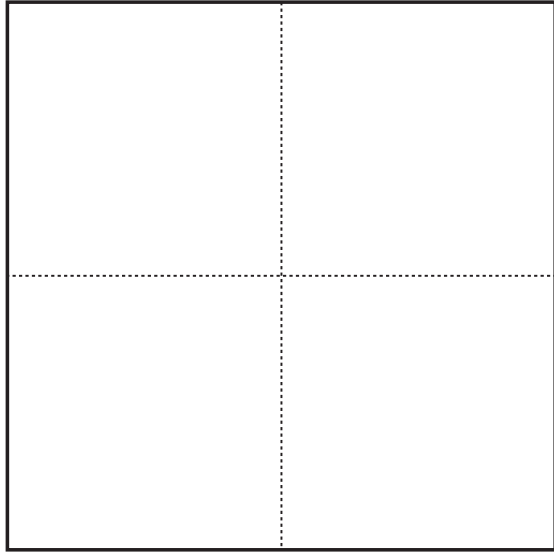

a)

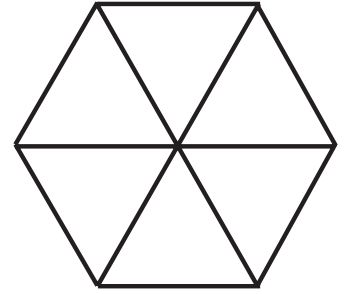
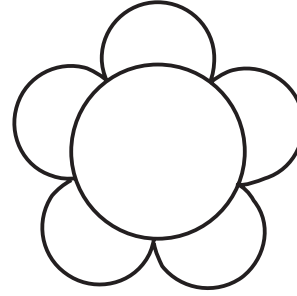
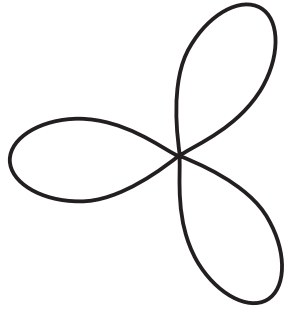
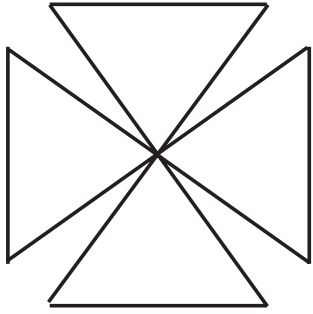

b)

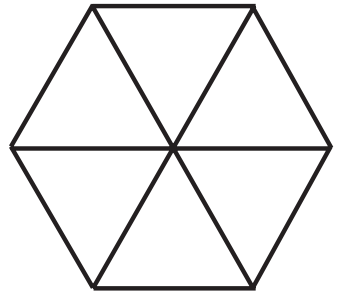
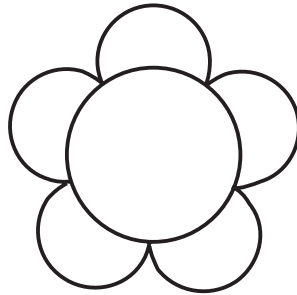
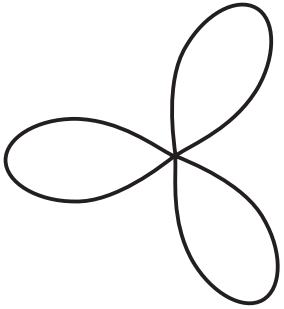
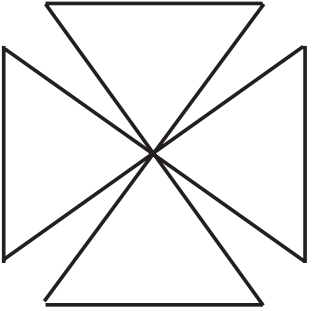

c)

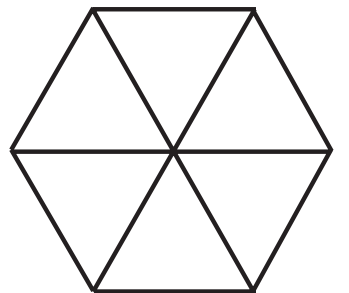
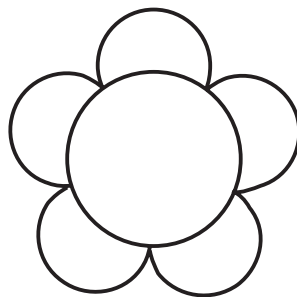
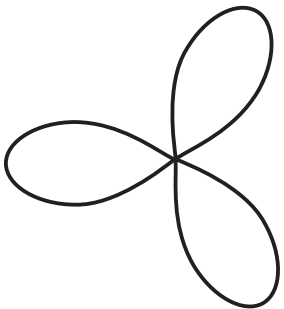
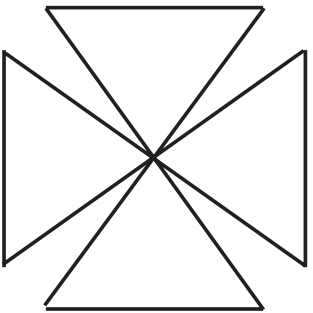

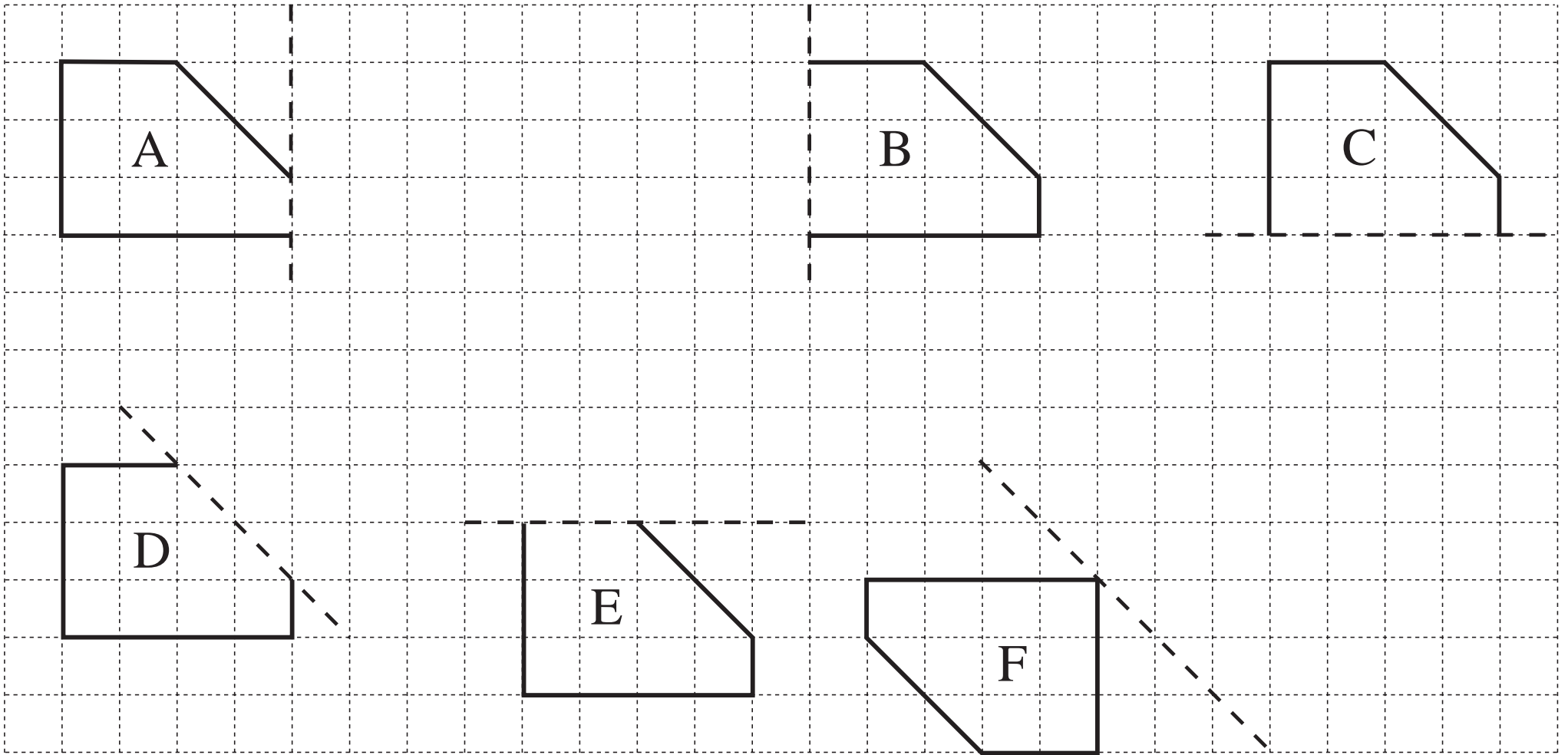

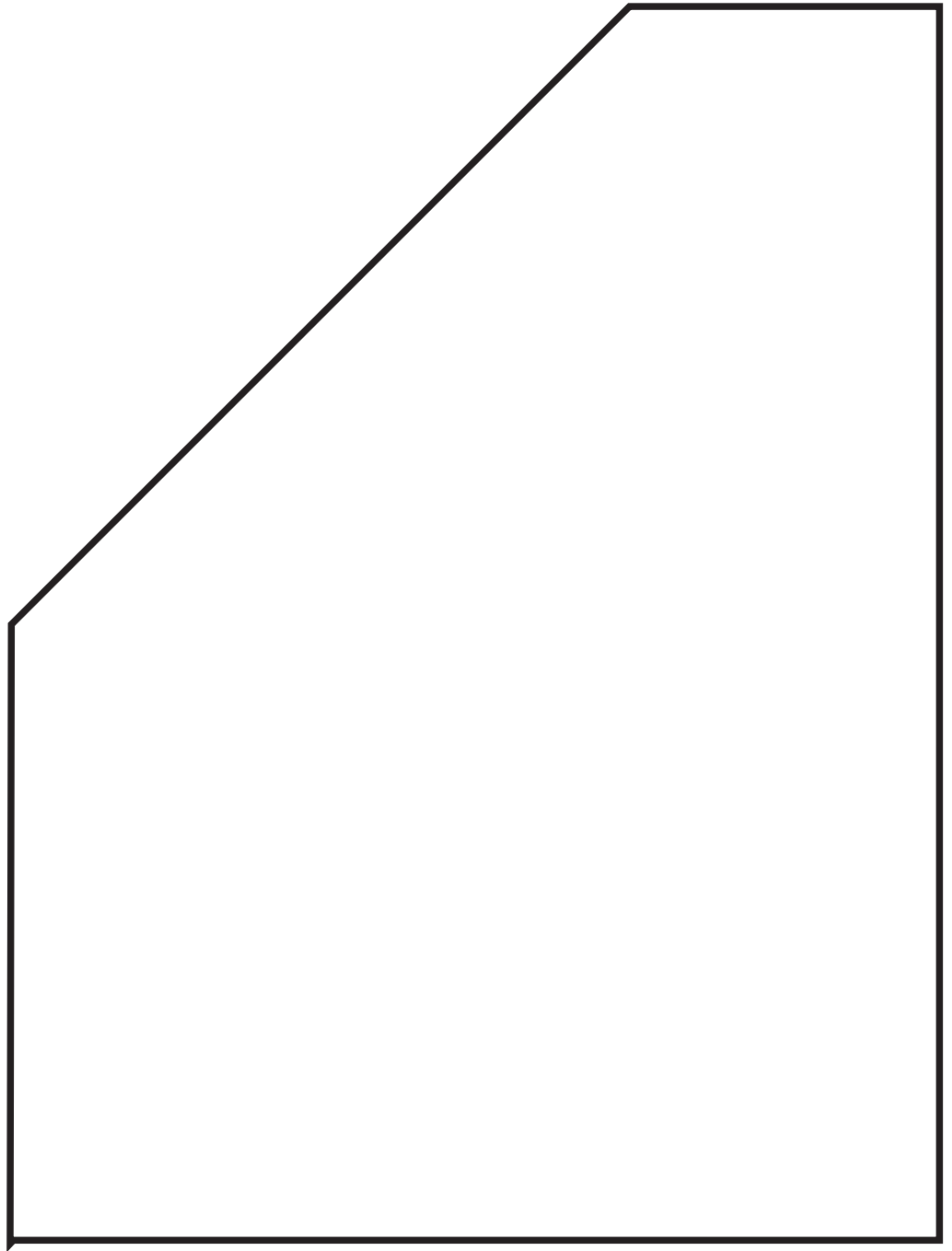
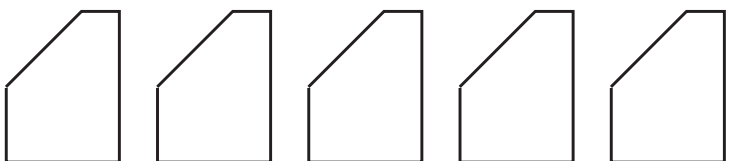
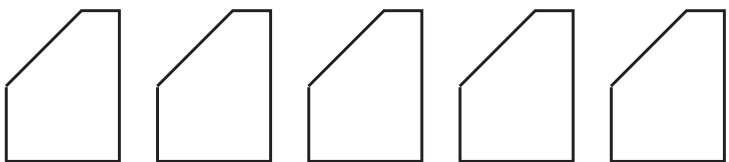
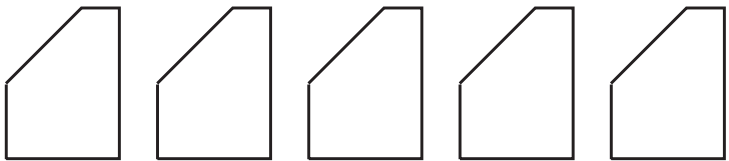
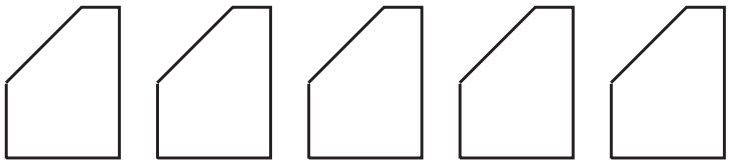
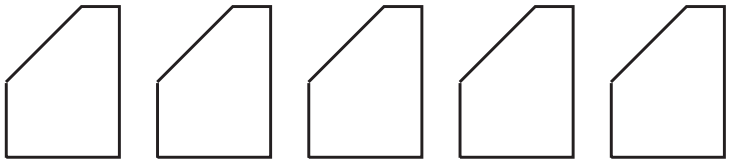
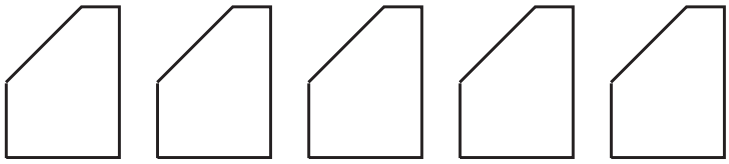

a)

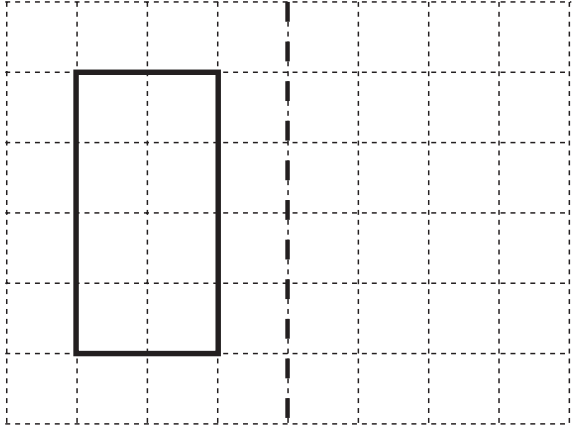

b)

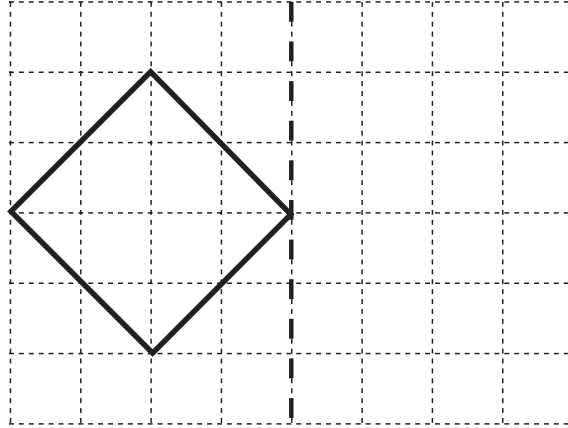

c)

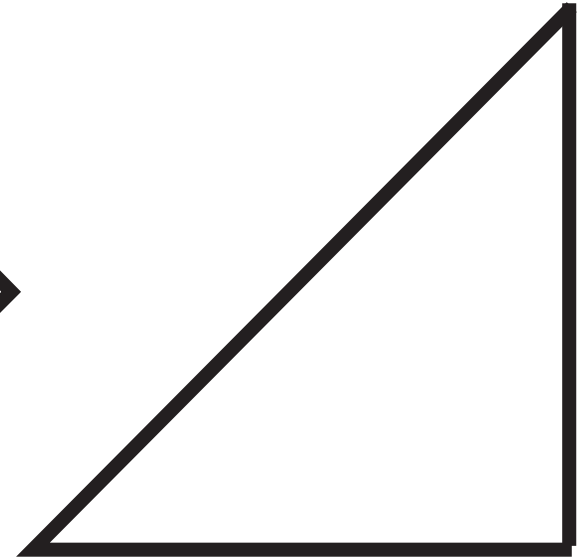
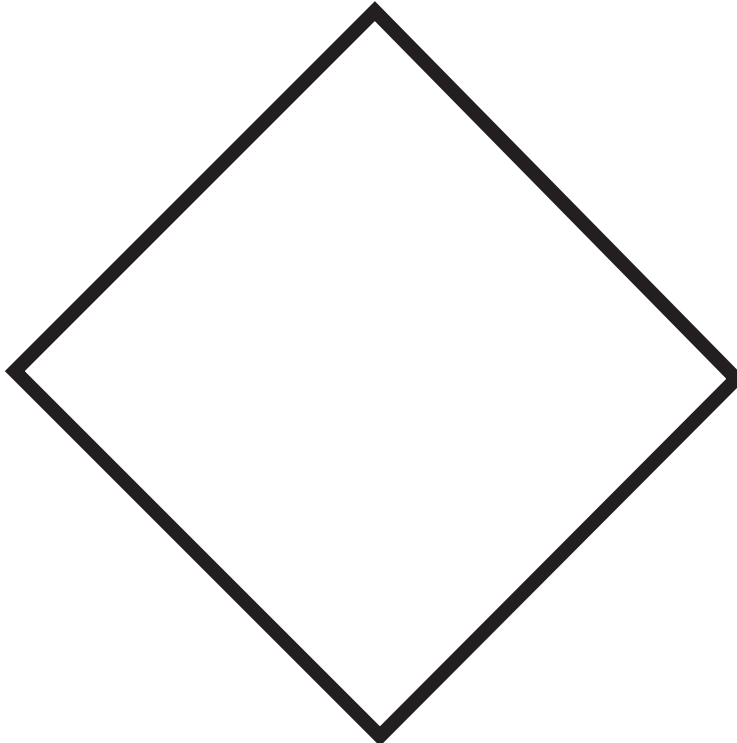
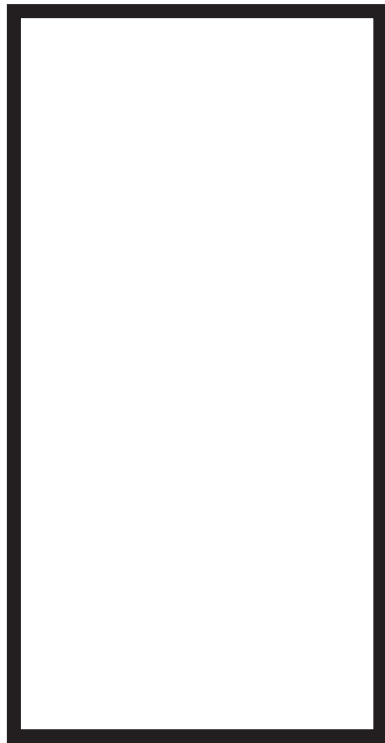
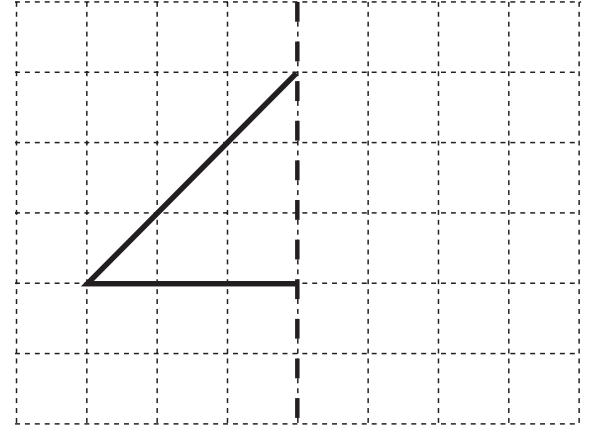

<i>C</i>	541			1014	
<i>J</i>		541			1014
<i>L</i>			541		1014

LP 112/1

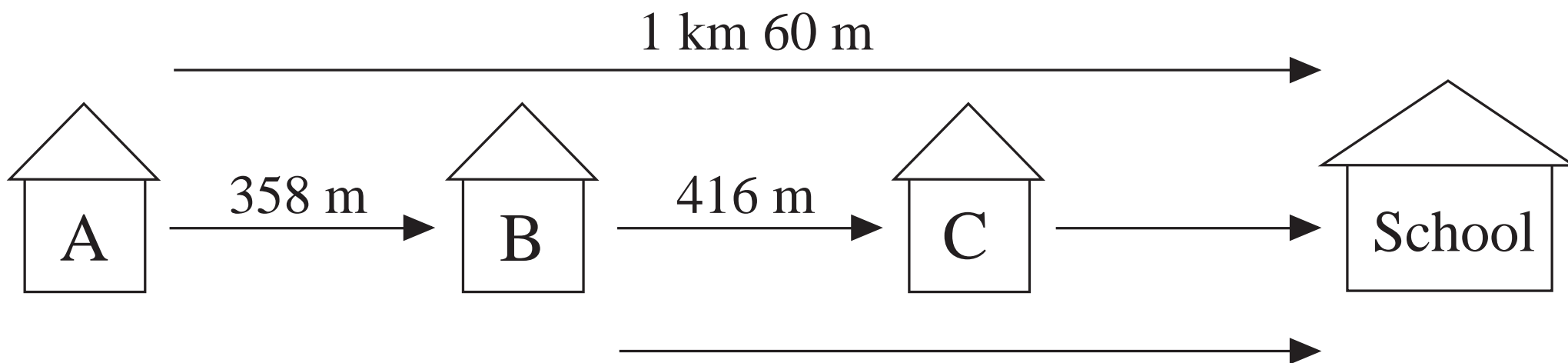

LP 112/2

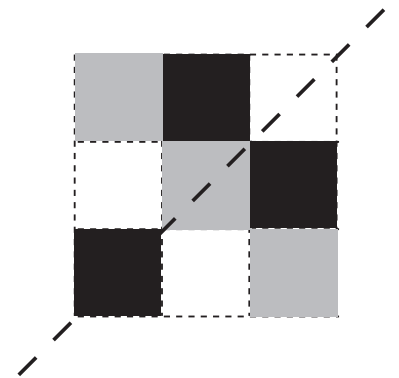
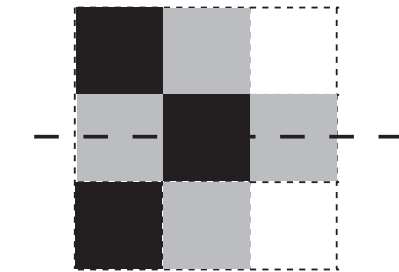
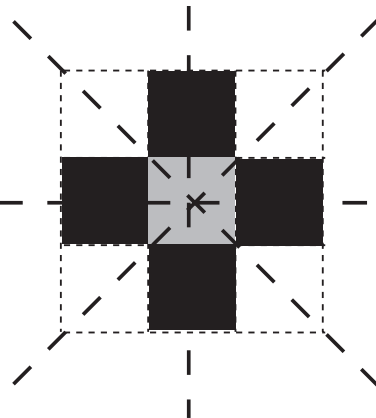
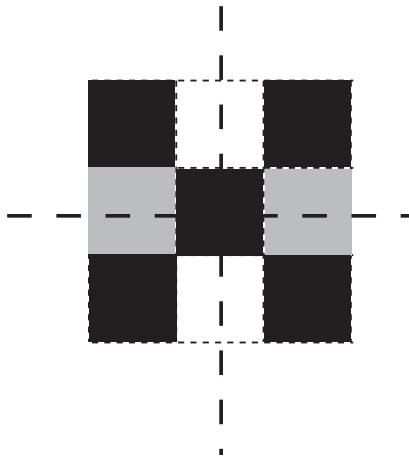
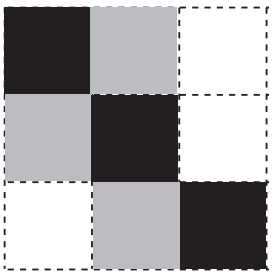
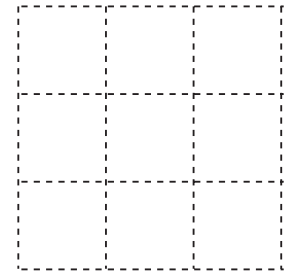
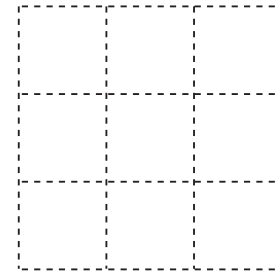
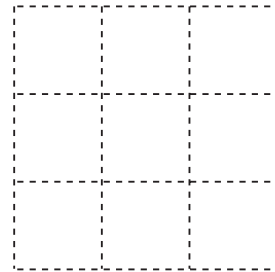
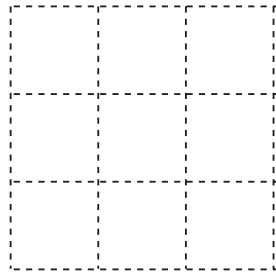
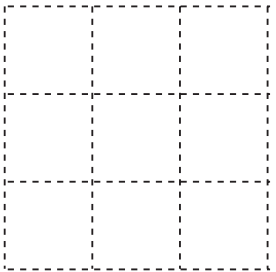
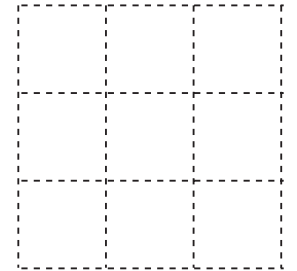
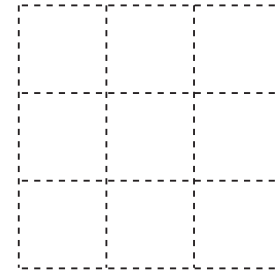
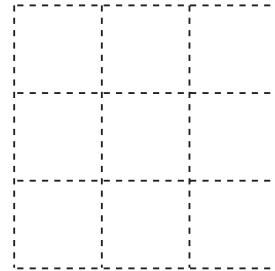
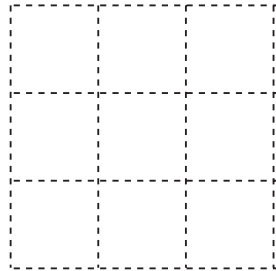
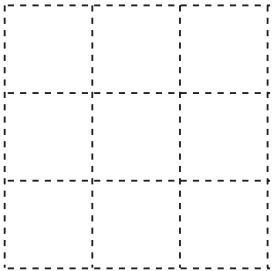
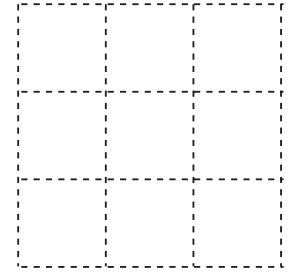
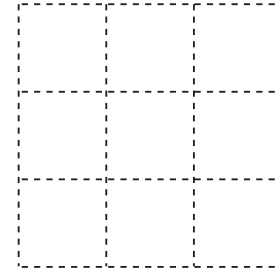
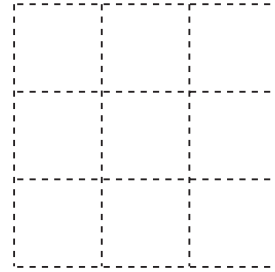
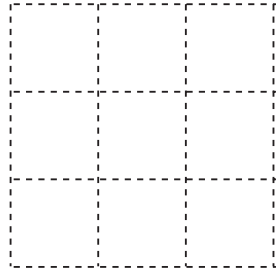
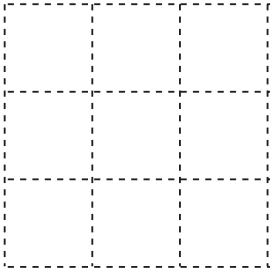

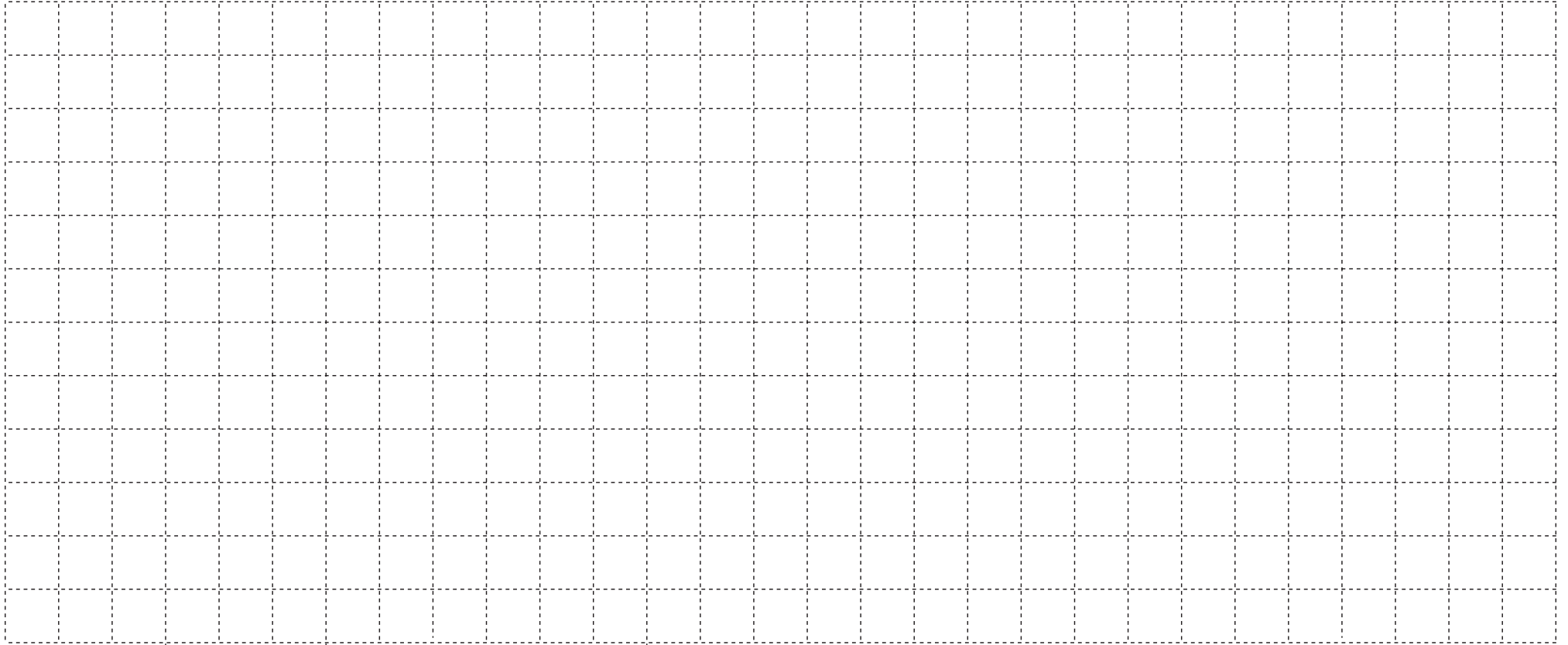

a)

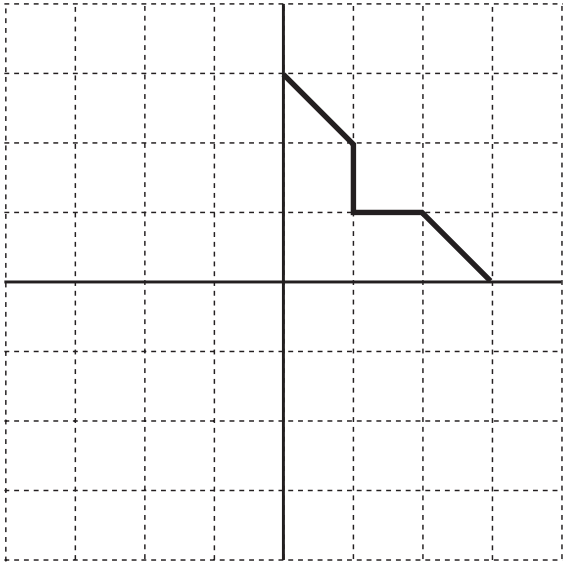

b)



c)

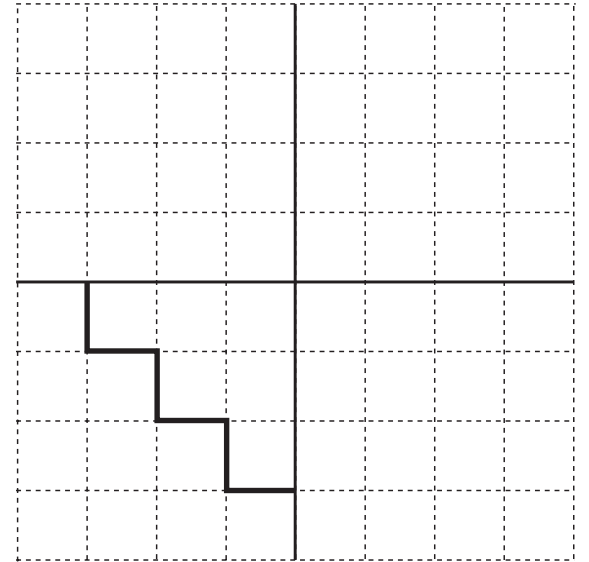

d)

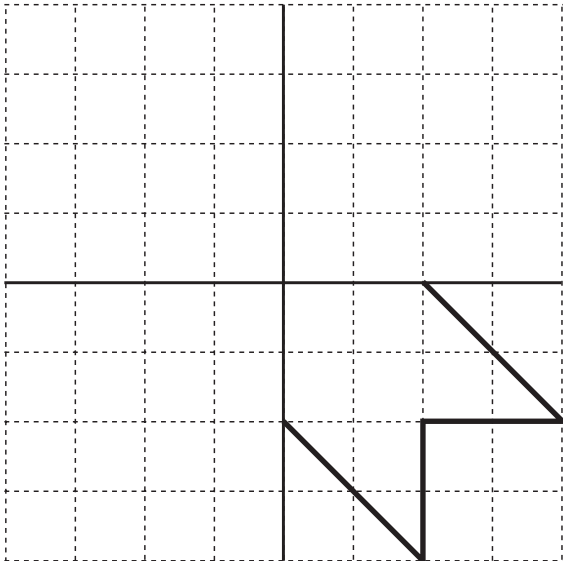

e)

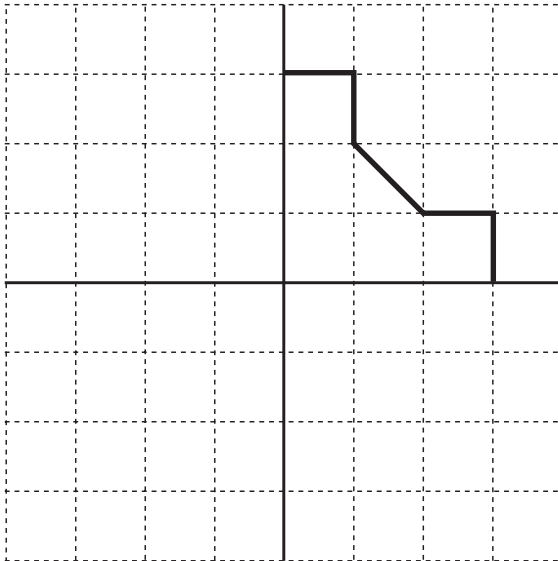

f)

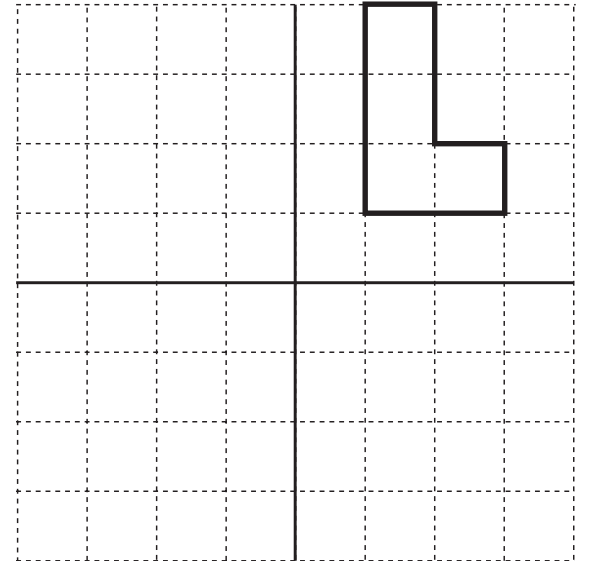

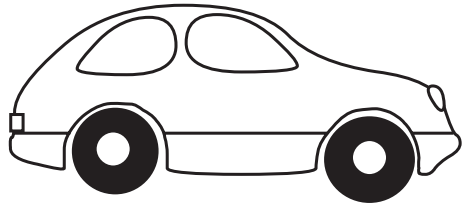

£6.75



£3.32

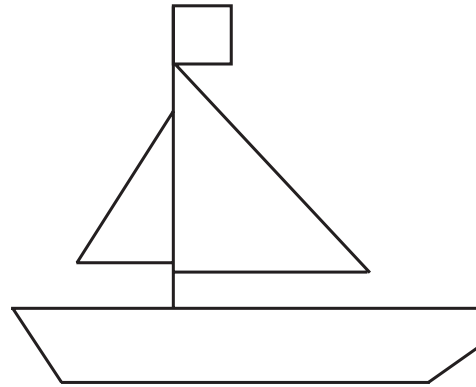

£8.54

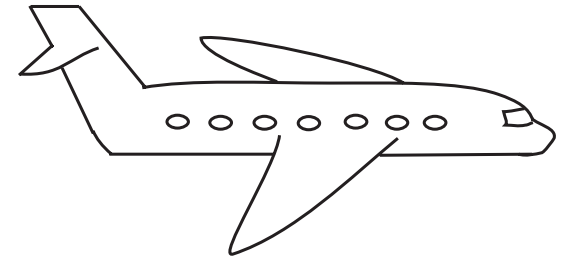

£4.99

LP 113/1

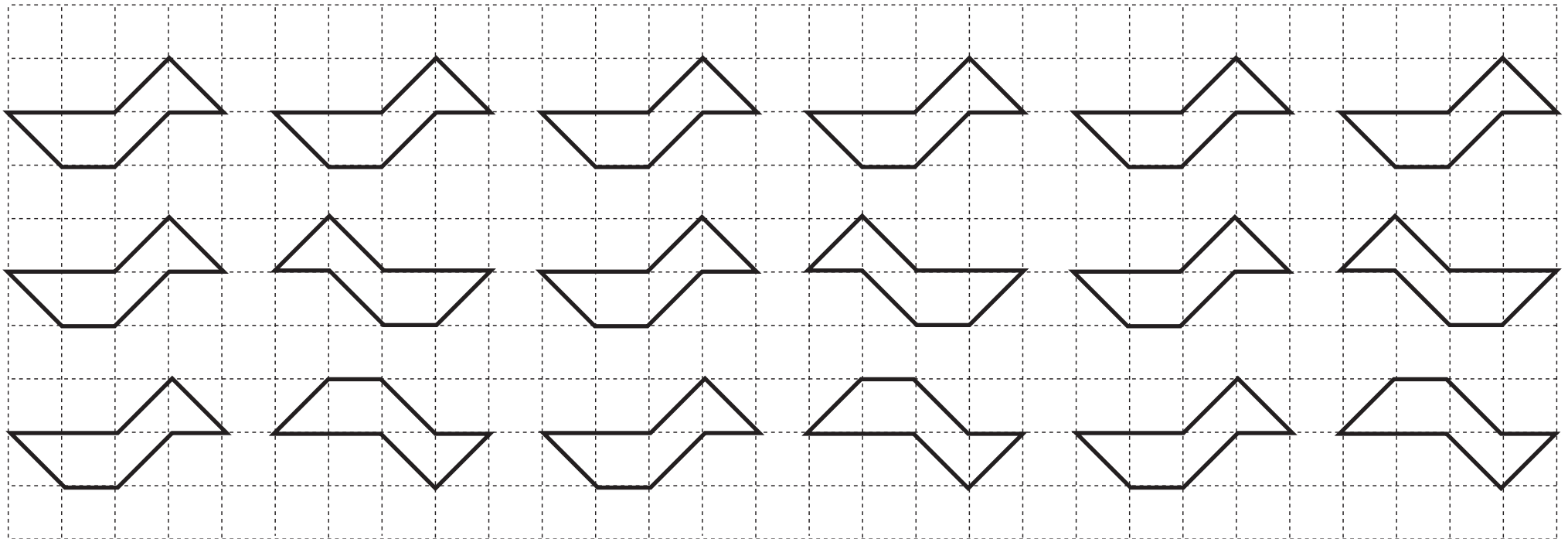

LP 113/5

a)

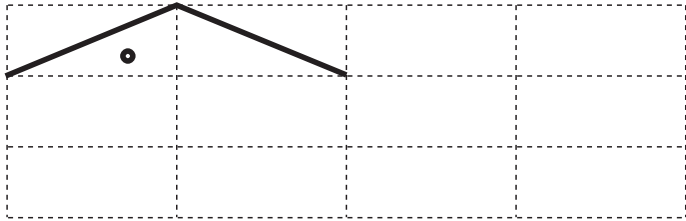

b)

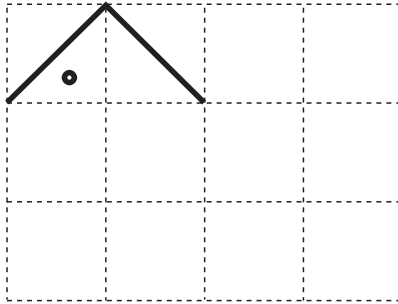

c)

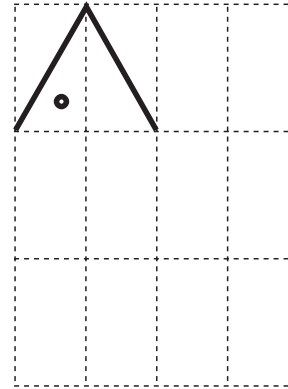

d)

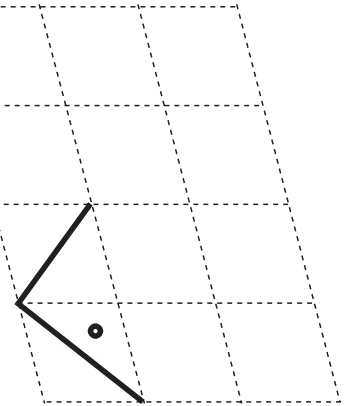

LP 113/7

a)

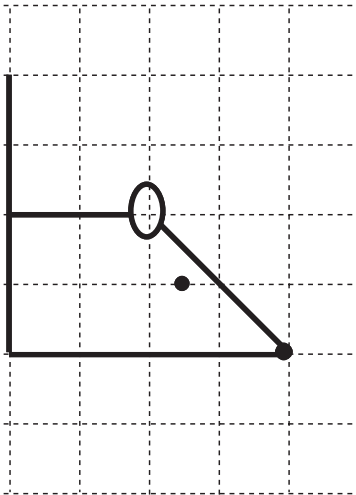

b)

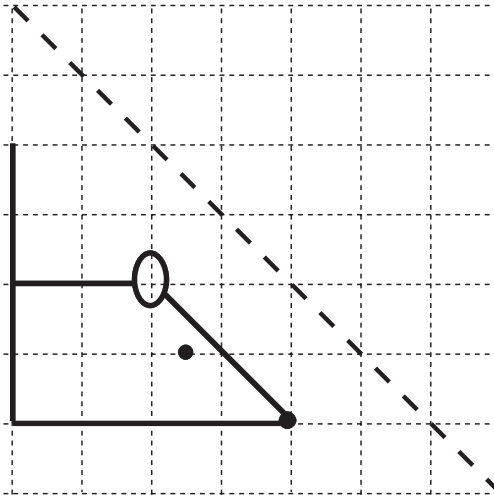

c)

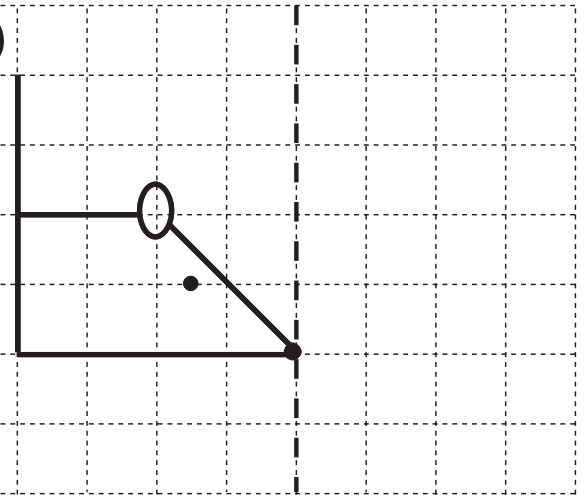

LP 113/8a

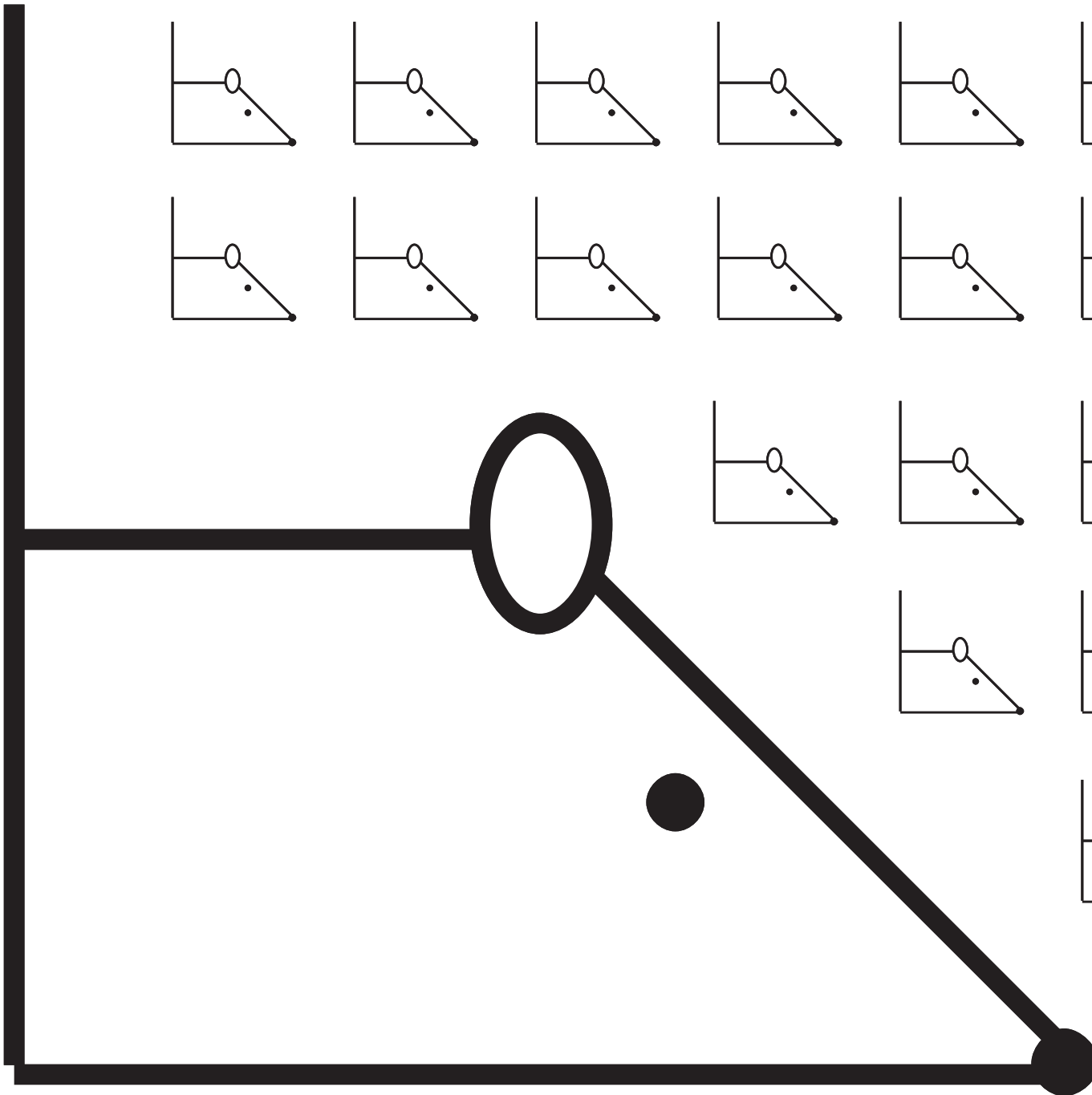
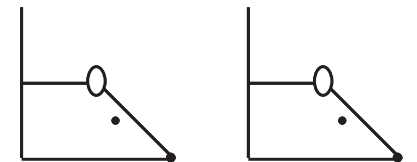
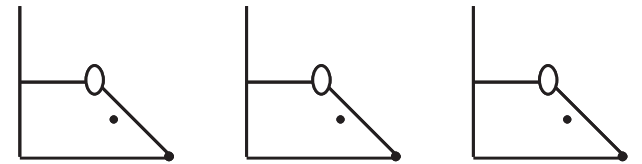
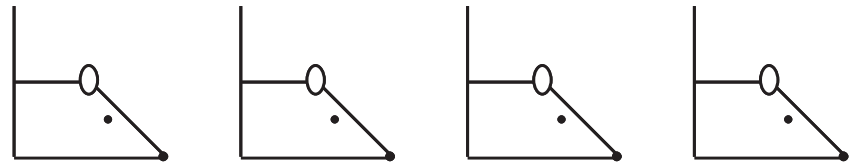
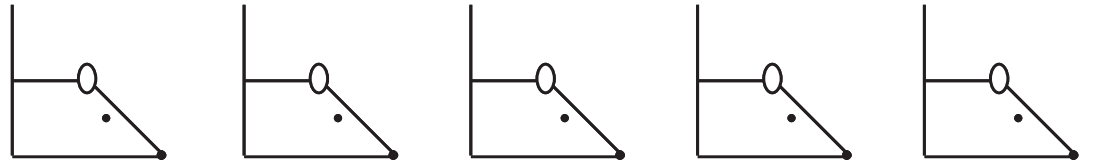
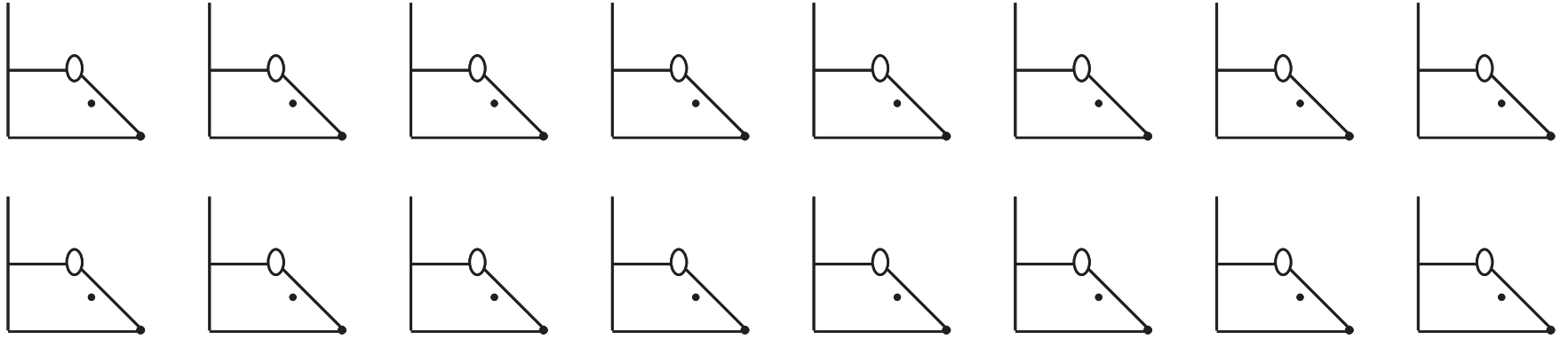

A

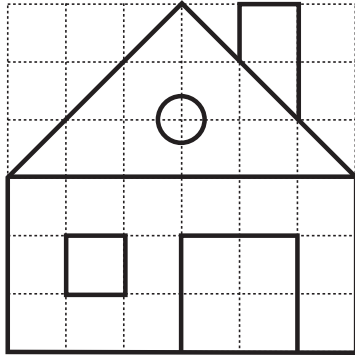

B

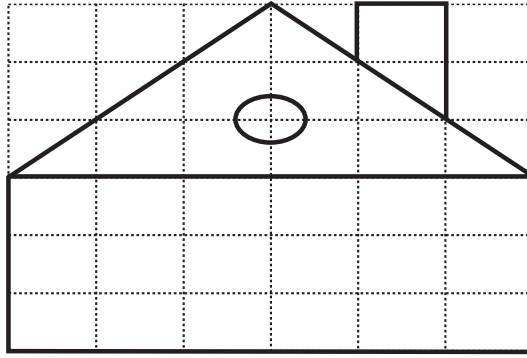

C

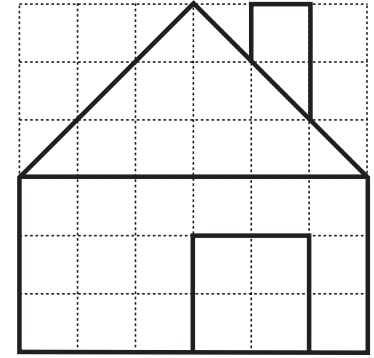

D

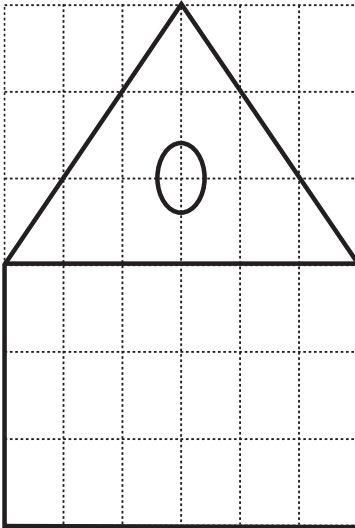

E

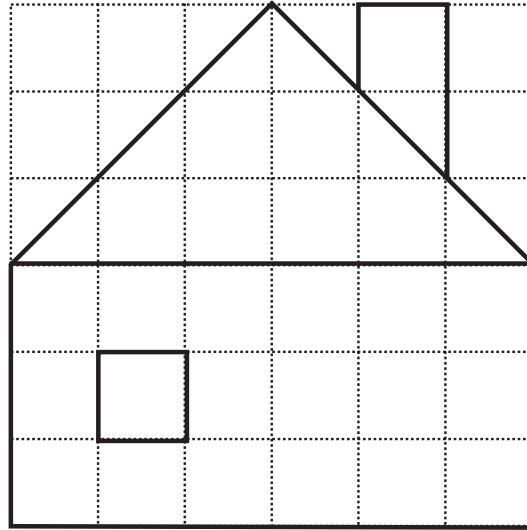

F

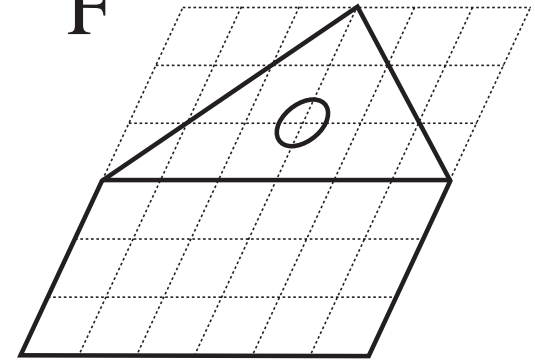

G

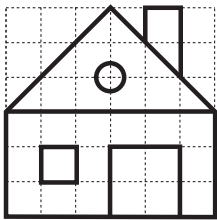

H

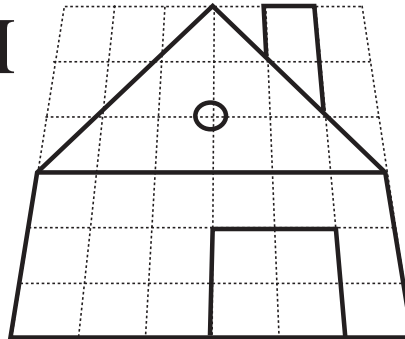

I

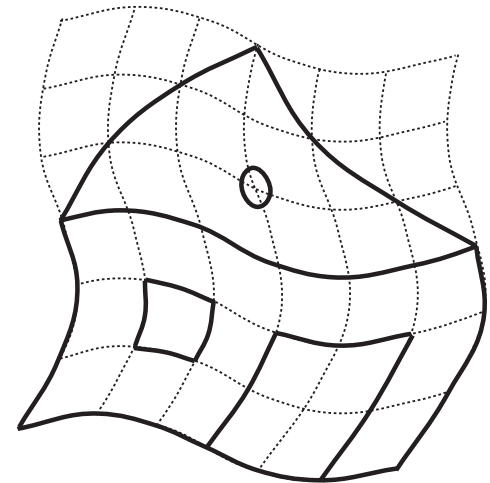

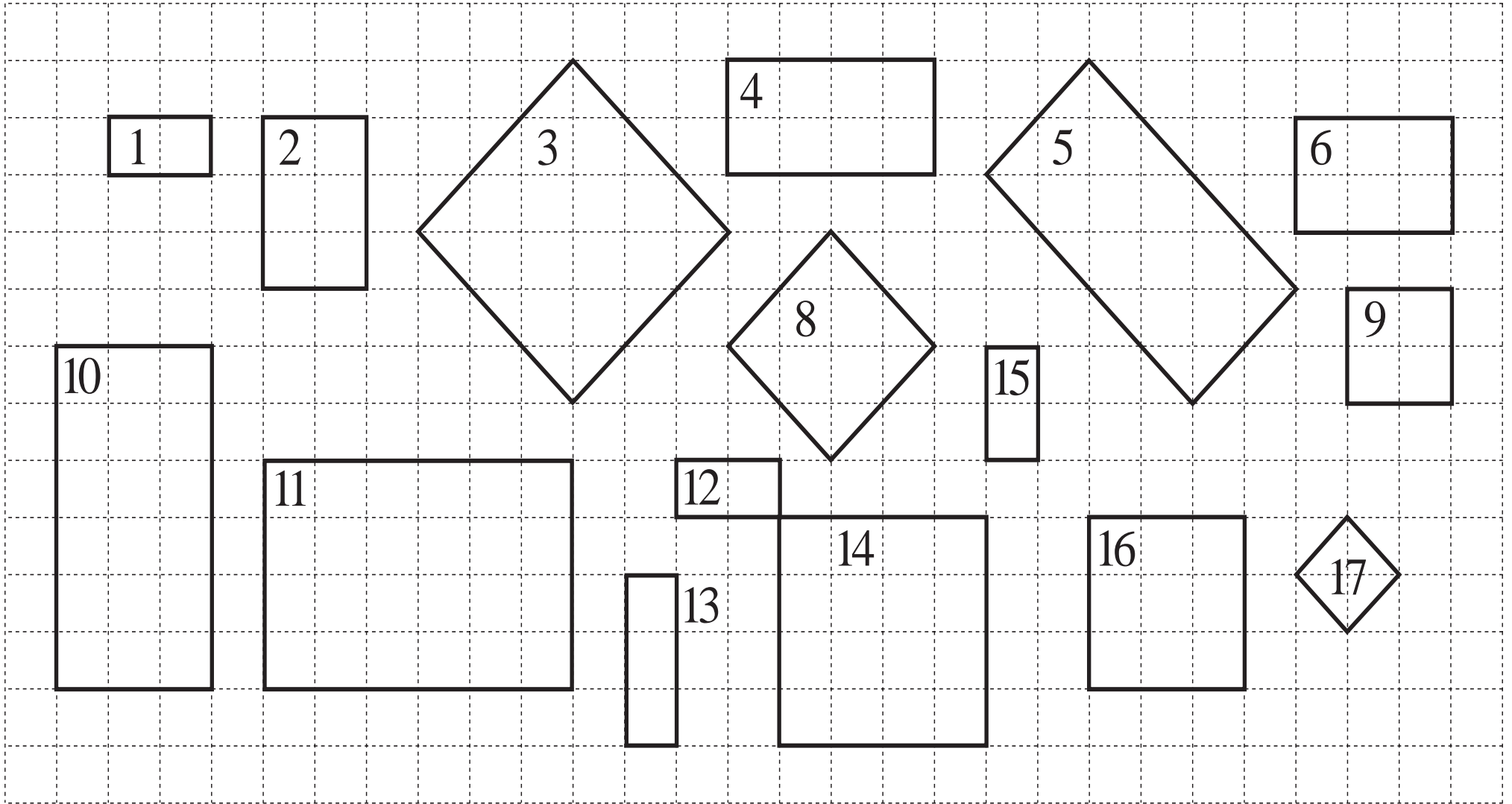

4 m

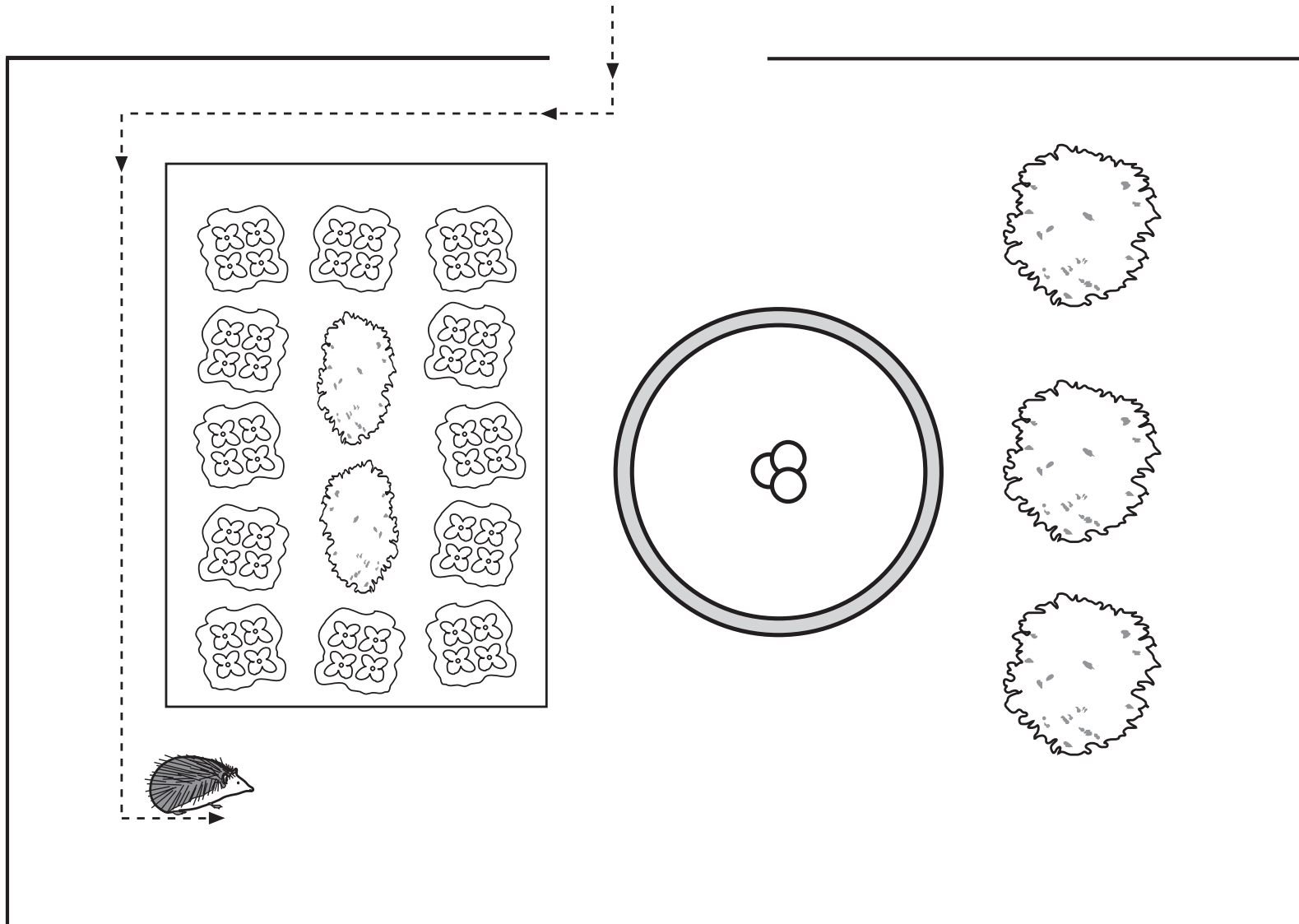
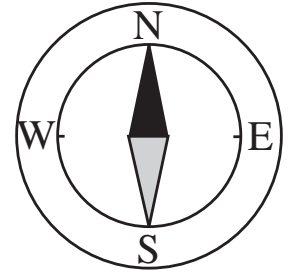

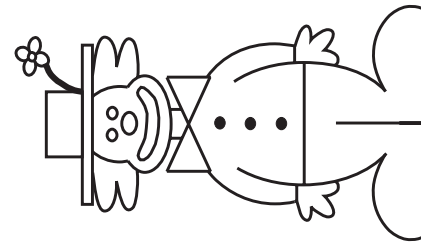
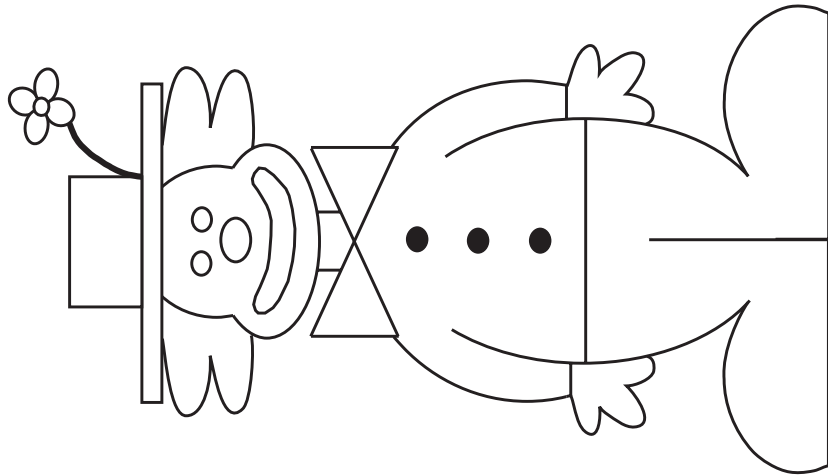
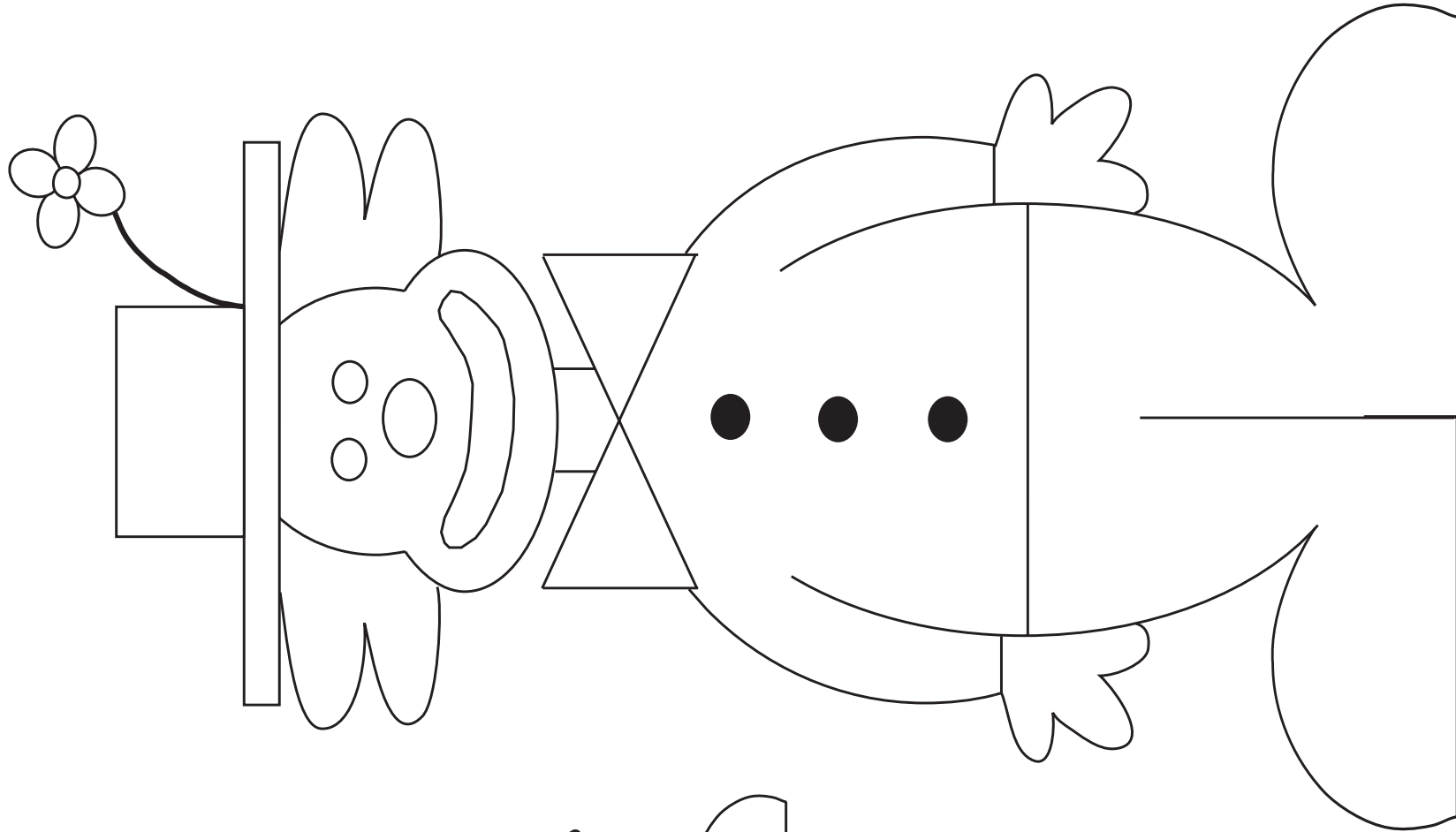

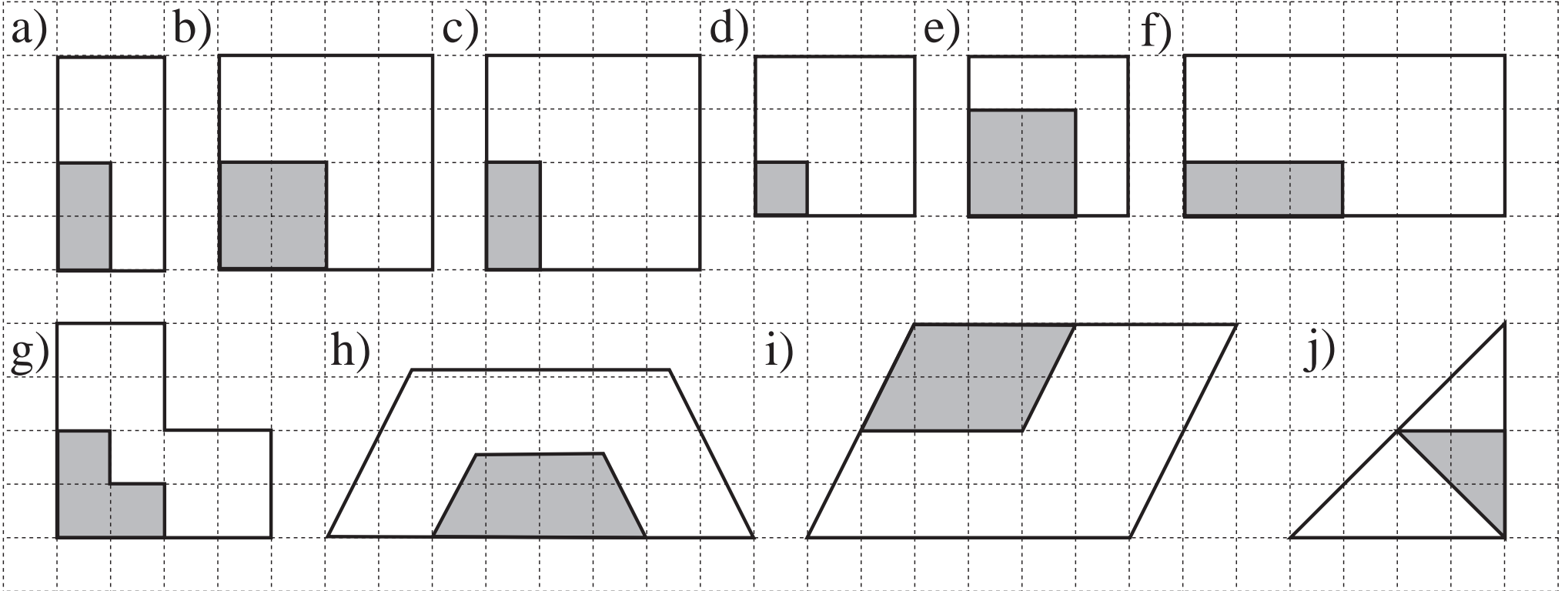

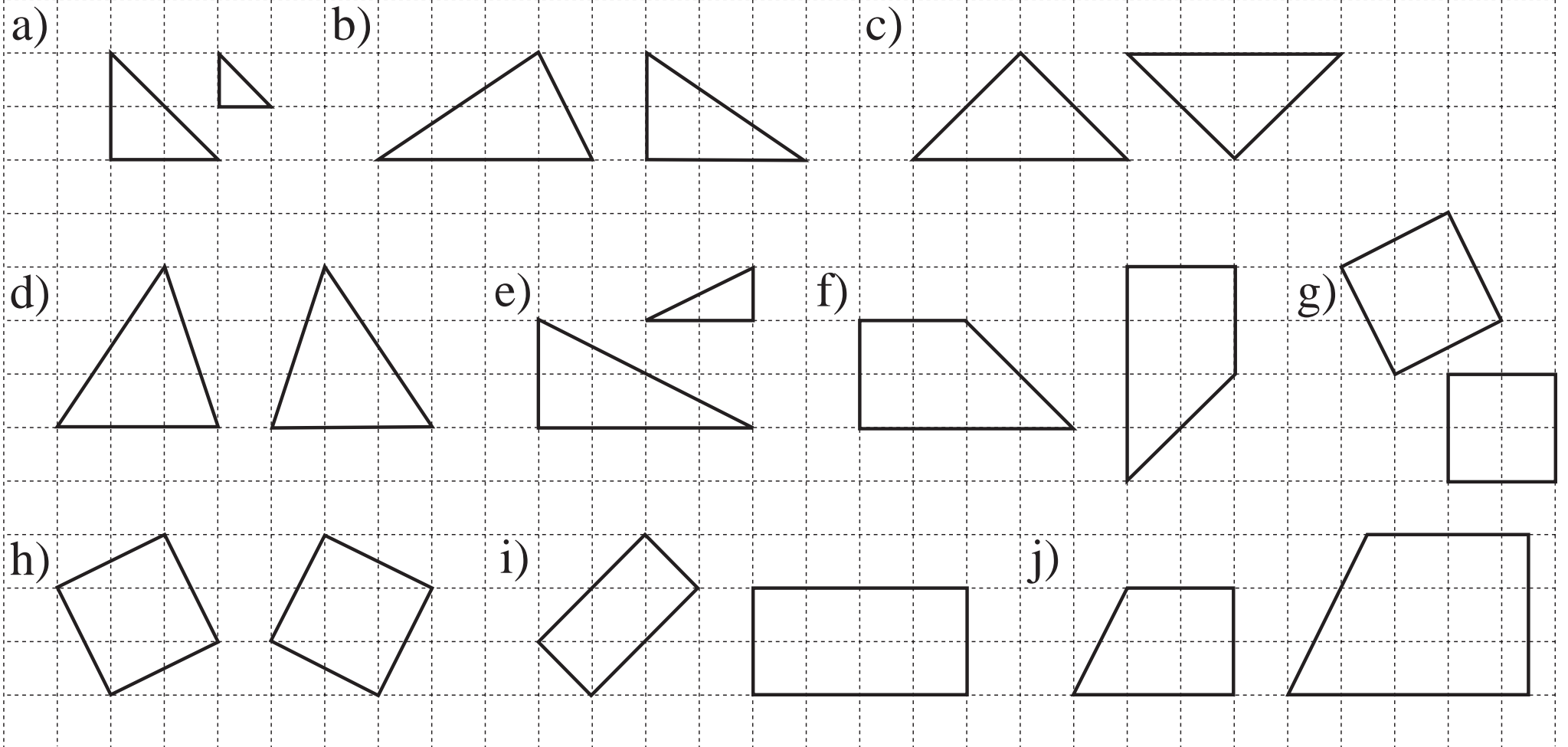

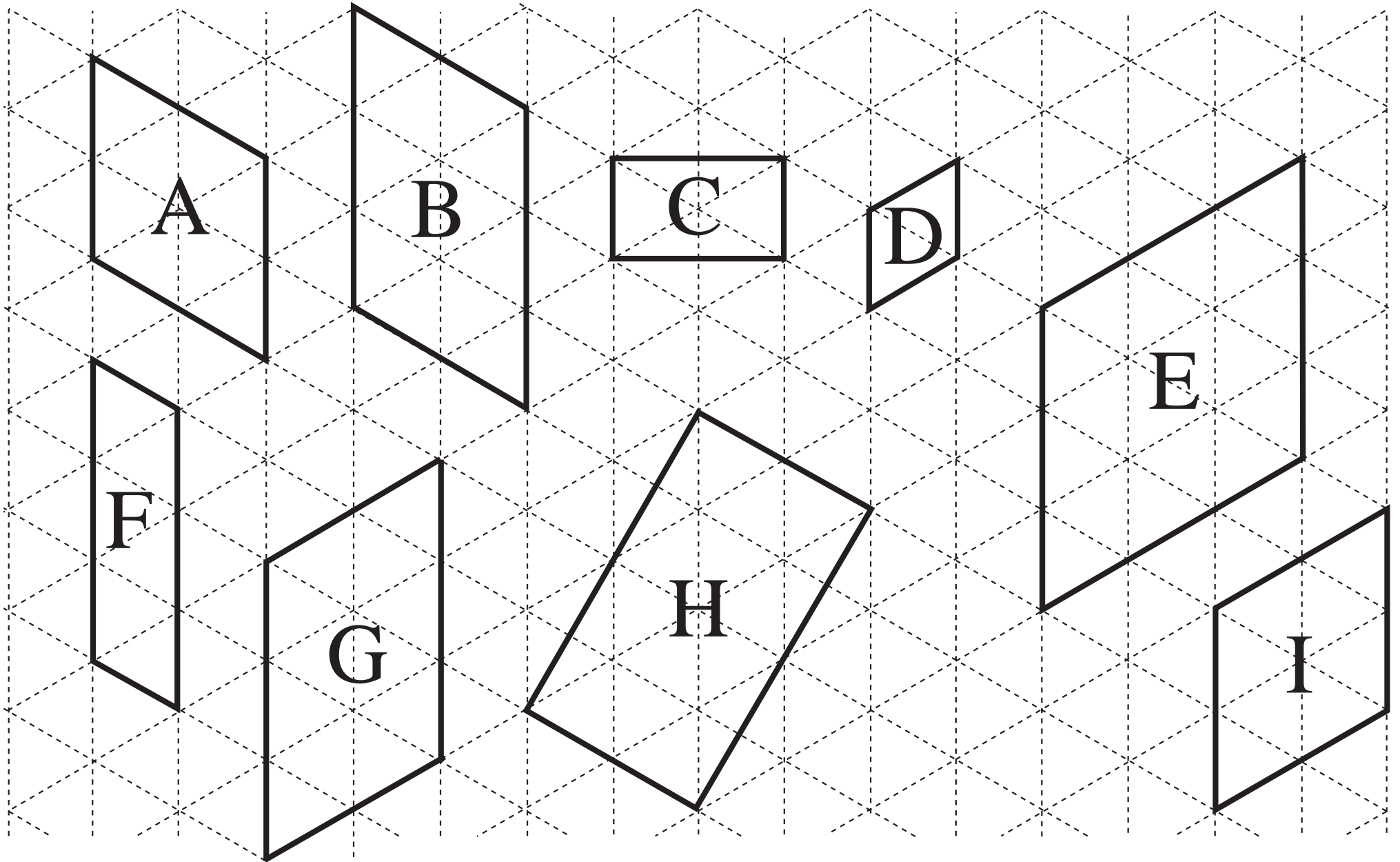

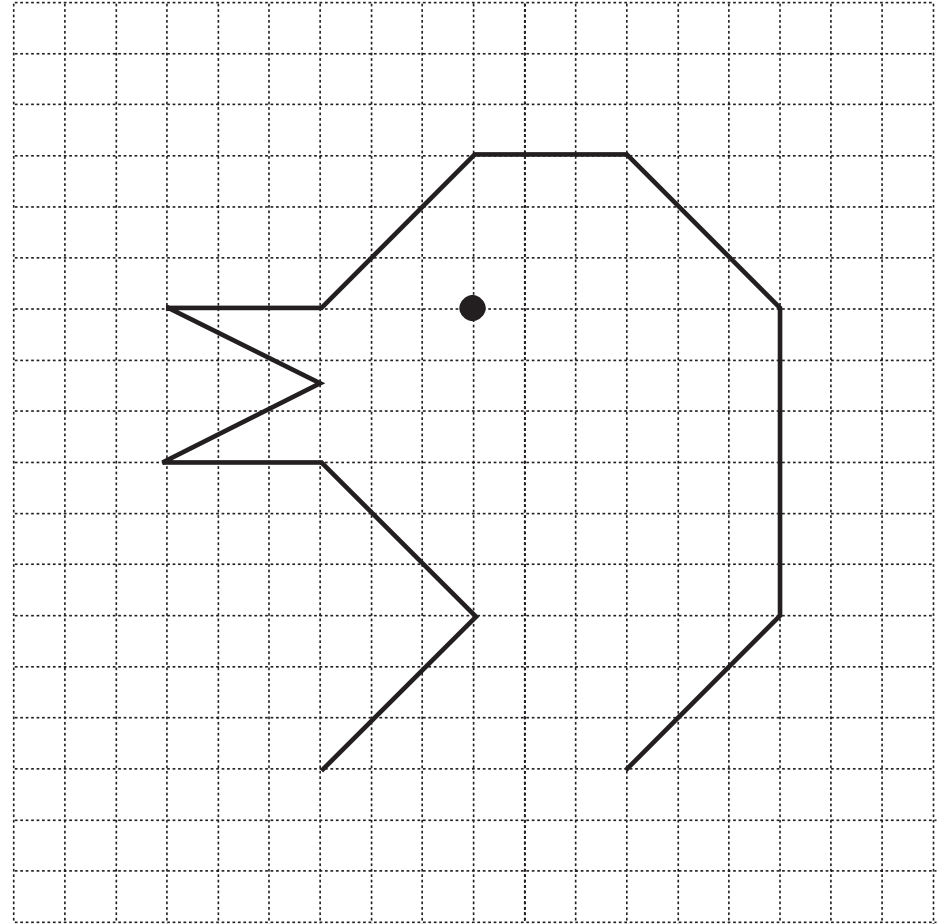
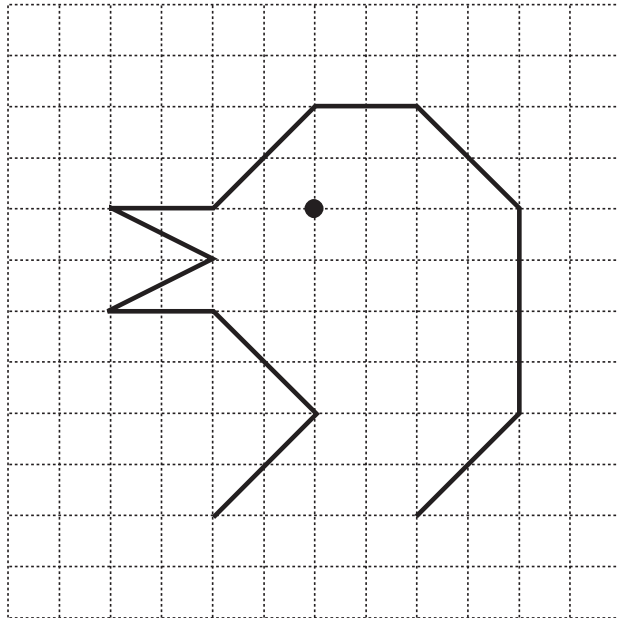
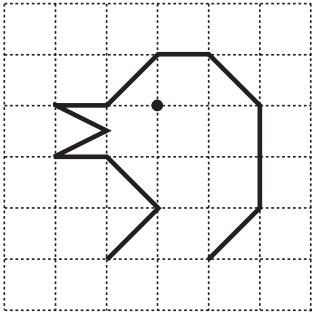

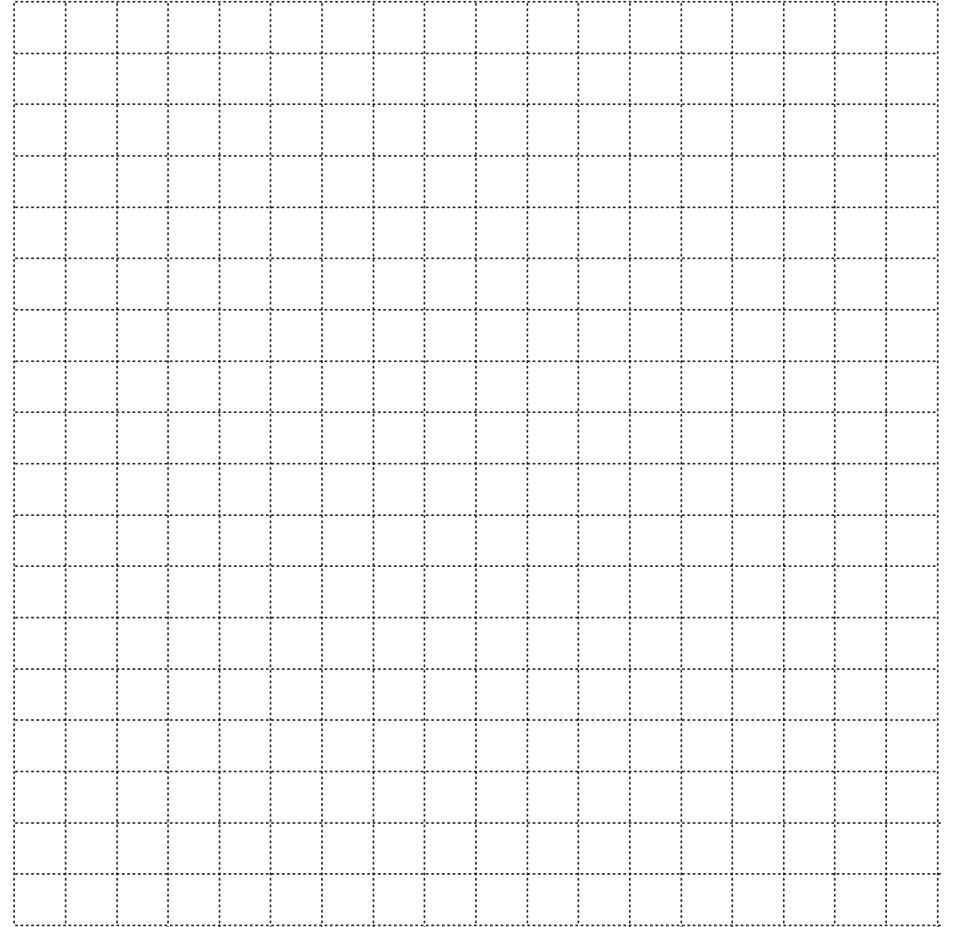
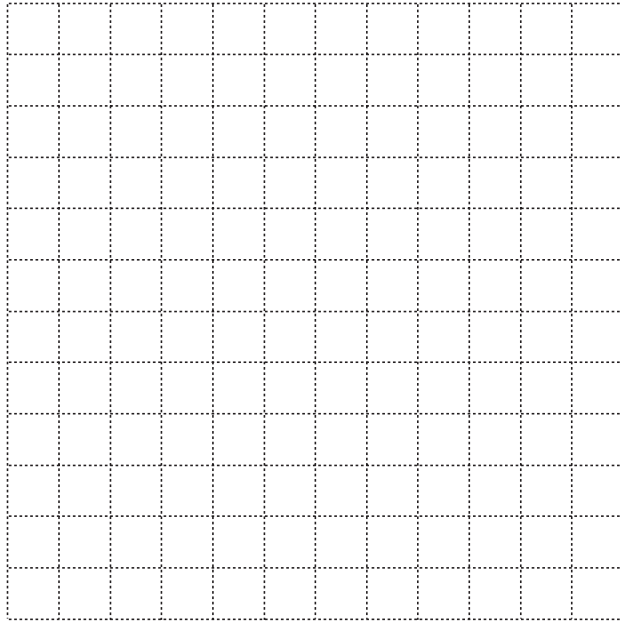
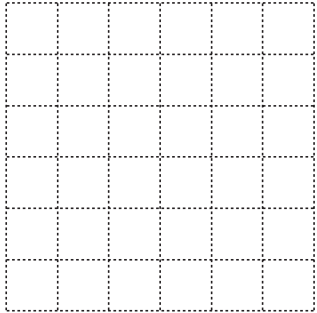

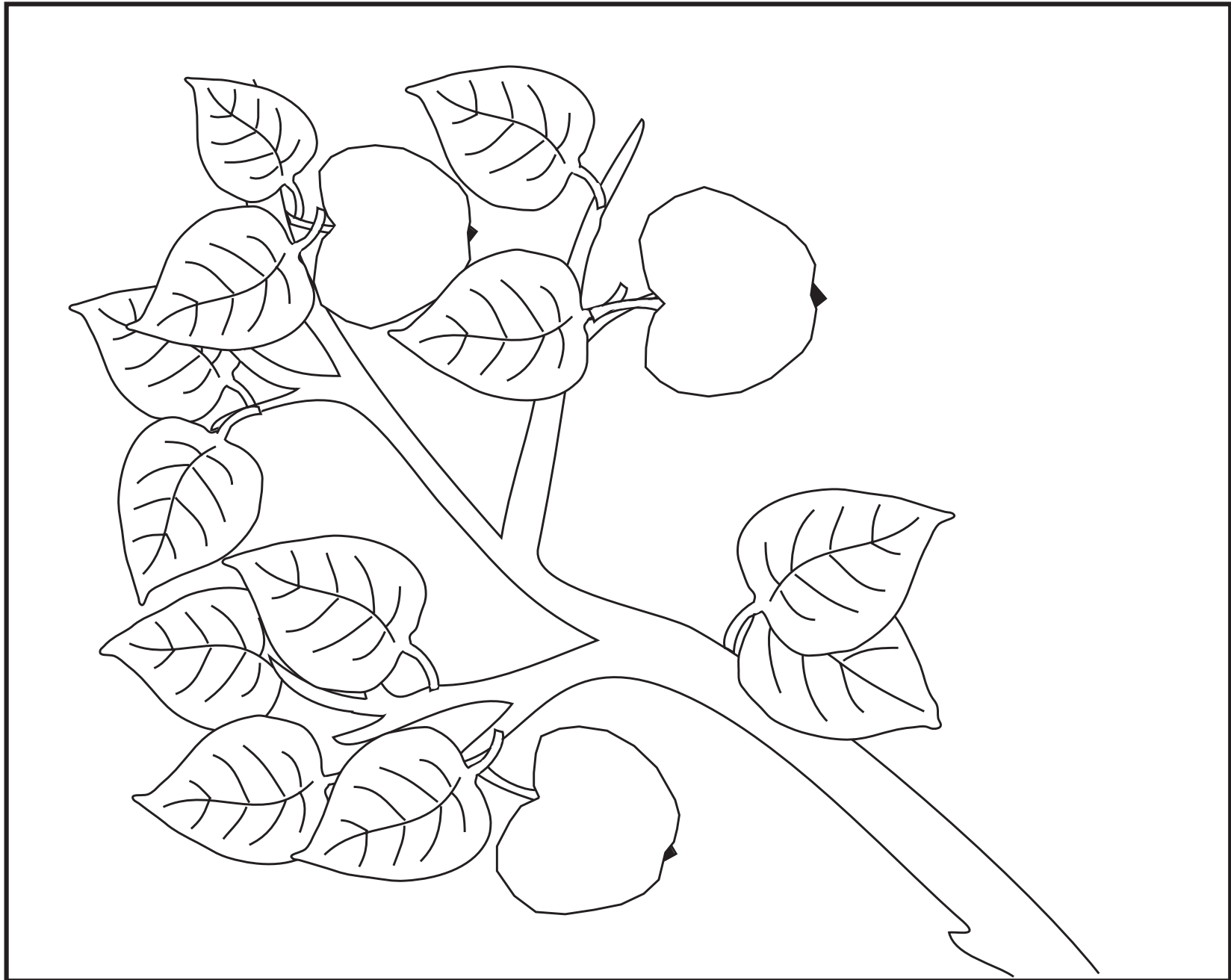

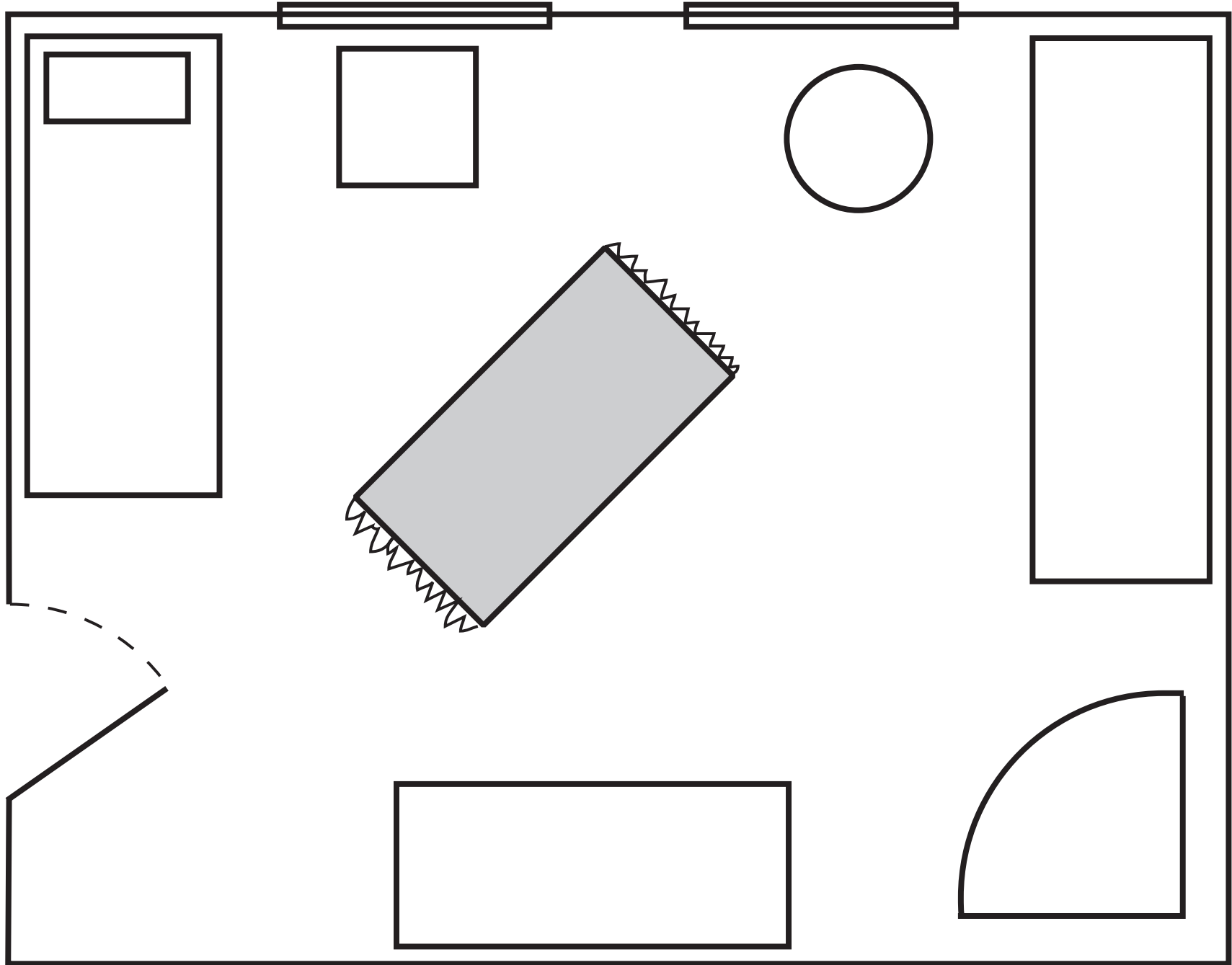

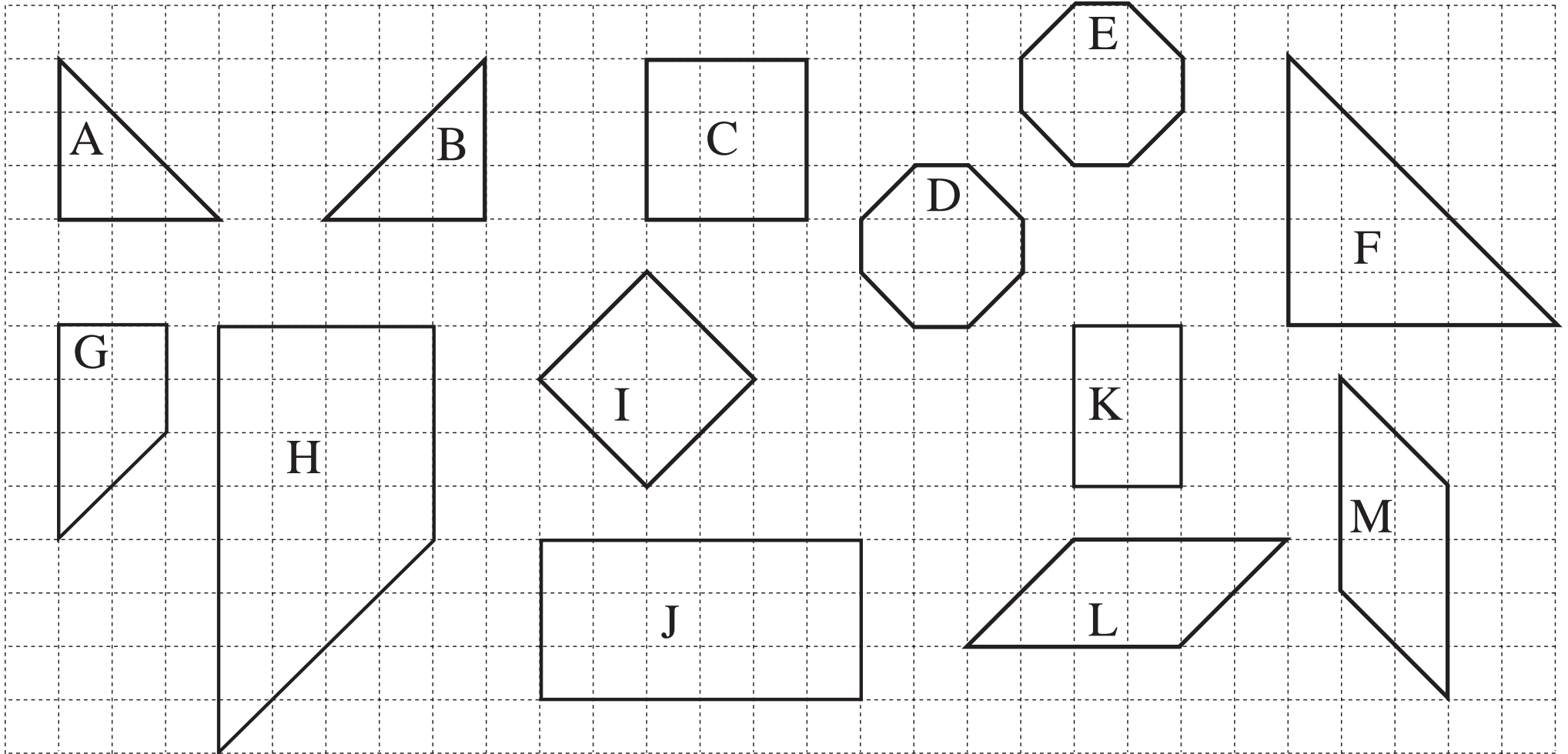

a) i)

	3	4	2
+			
<hr/>			
	5	8	9

ii)

	5	4	6
+			
<hr/>			
1	3	7	6

iii)

4	0	3
+		
<hr/>		
9	4	3

iv)

	9	9	9
+			
<hr/>			
1	8	8	8

v)

	3		2
+		4	6
<hr/>			
	2	5	

vi)

1		8	
+		0	3
<hr/>			
2	4		

b) i)

9	5	6
-		
<hr/>		
6	1	4

ii)

7	4	3
-		
<hr/>		
1	5	2

iii)

-	5	2	6
<hr/>			
3	1	2	

iv)

-	4	7	9
<hr/>			
2	1	8	

v)

8	5		
-		3	4
<hr/>			
6		2	

vi)

7		1	
-	5	9	
<hr/>			
	5	2	

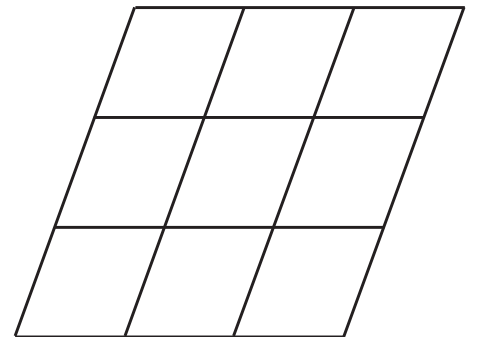
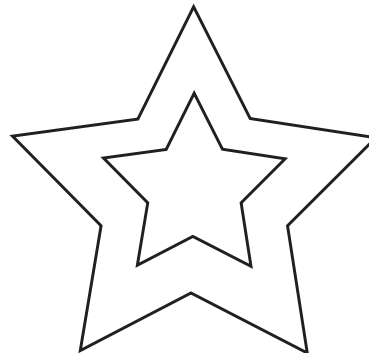
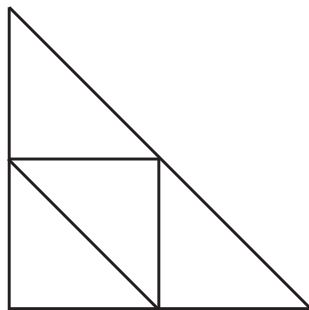
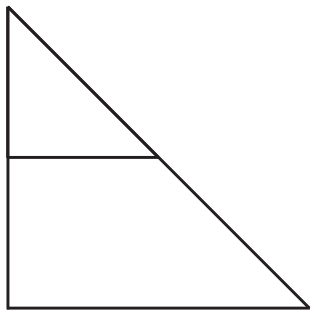
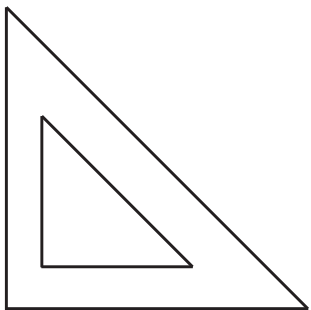
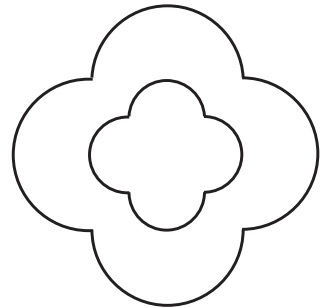
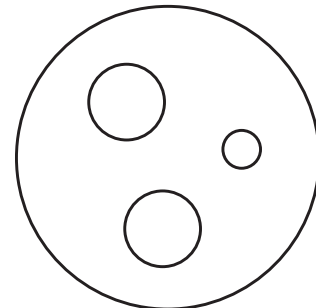
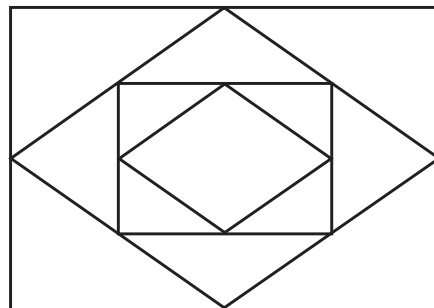
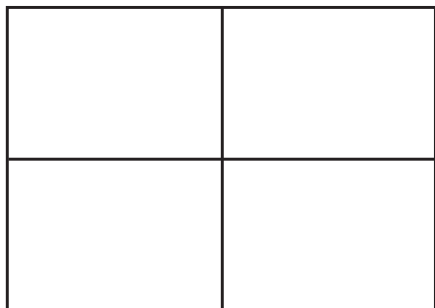
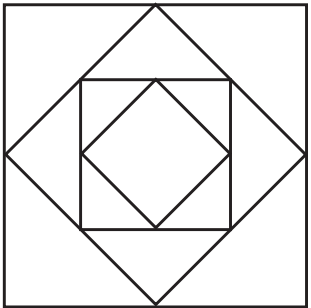
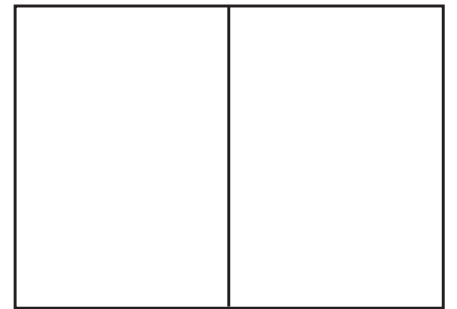
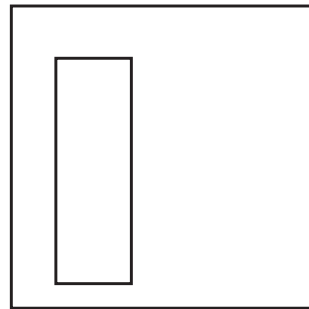
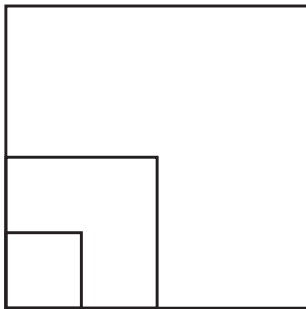
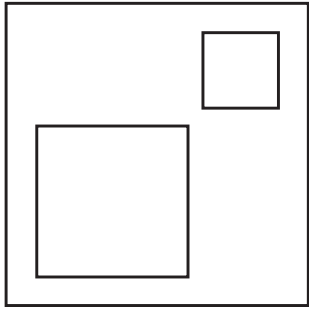
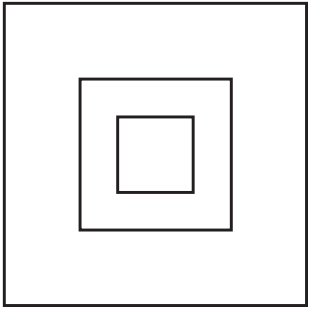

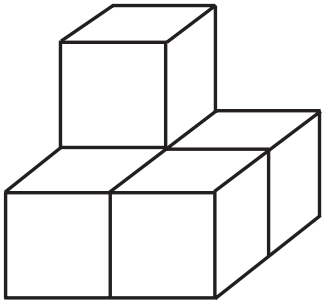

2	1
1	1

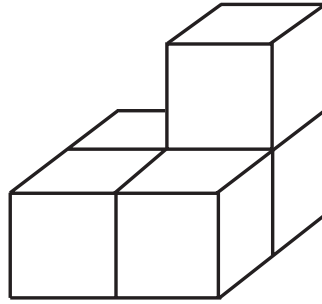

1	2
1	1

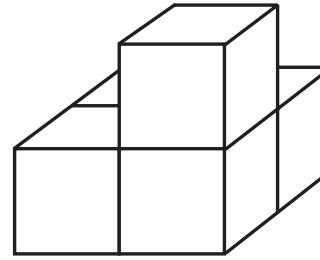

1	1
1	2

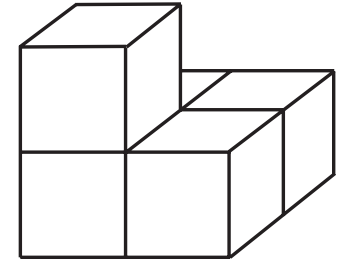

1	1
2	1

LP 118/6

<i>Solids</i>	a)	b)	c)	d)	e)
<i>Volume</i> (unit cubes)					
<i>Area</i> (unit squares)					

LP 118/7b

a)

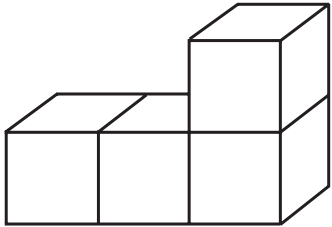

unit cubes

b)

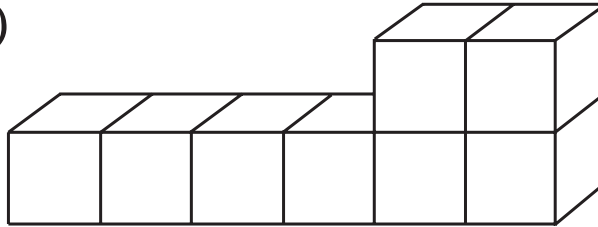

unit cubes

c)

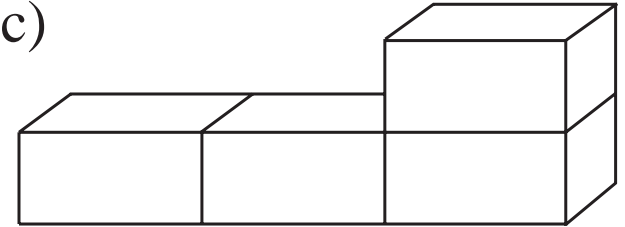

2-unit cuboids

d)

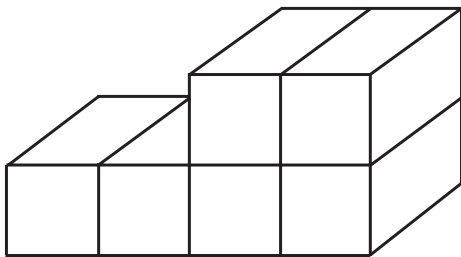

2-unit cuboids

e)

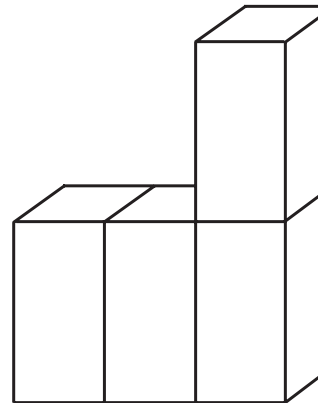

2-unit cuboids

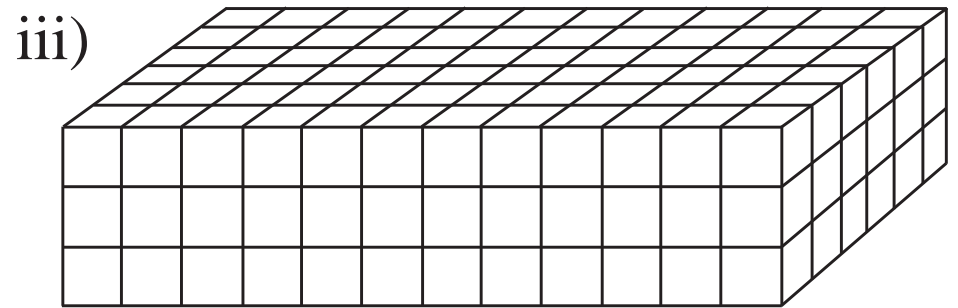
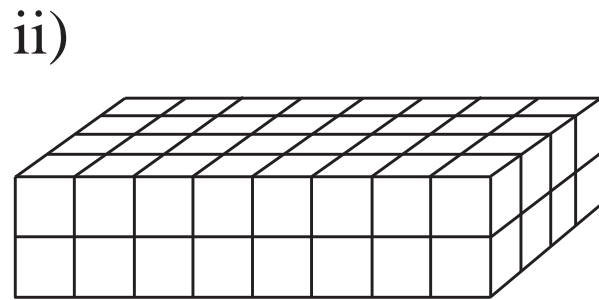
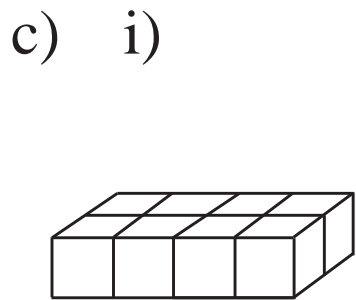
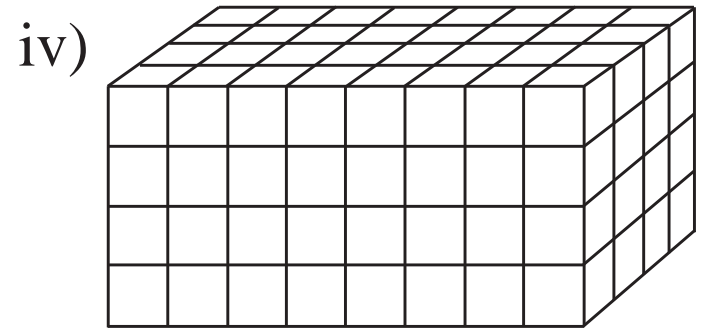
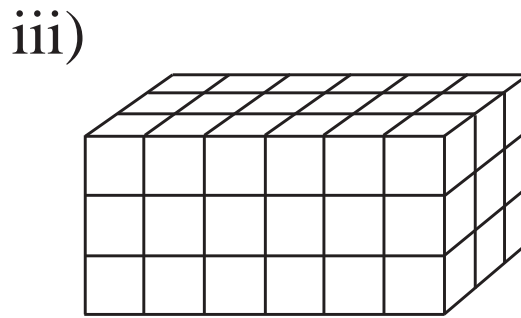
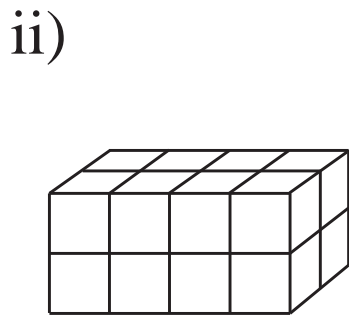
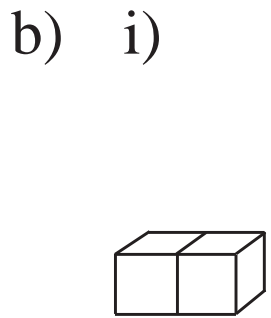
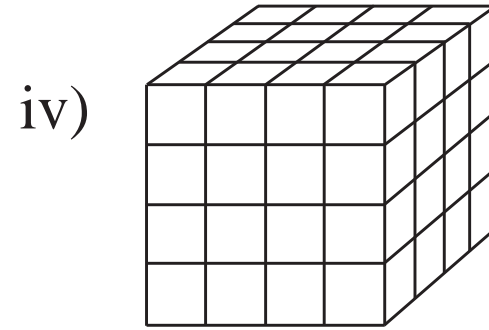
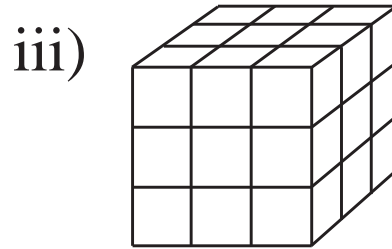
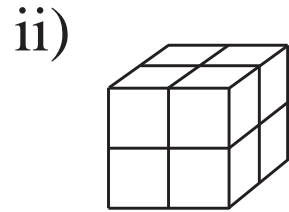
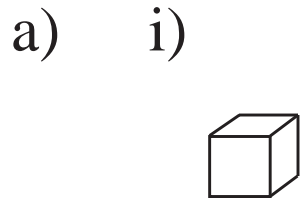

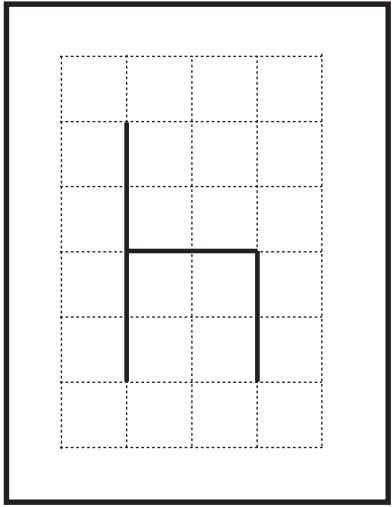

a)

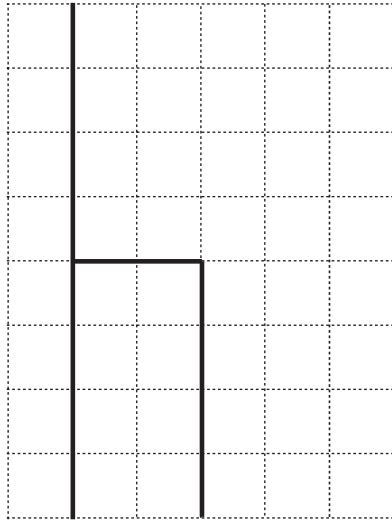

b)

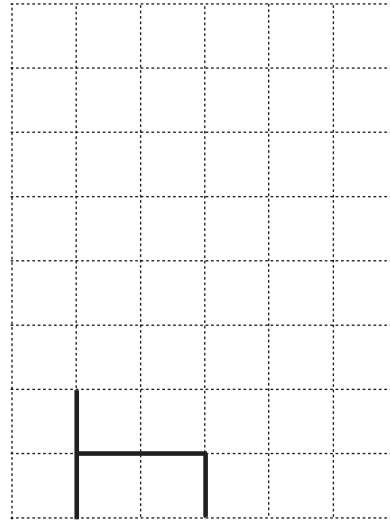

c)

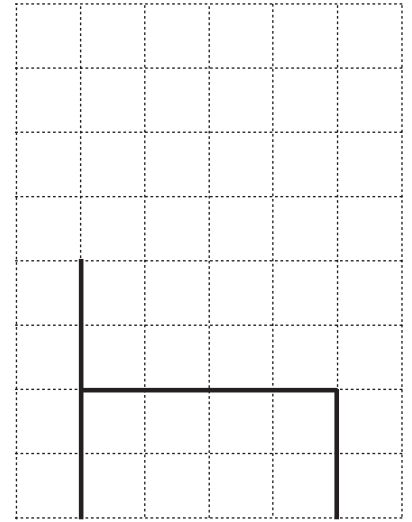

d)

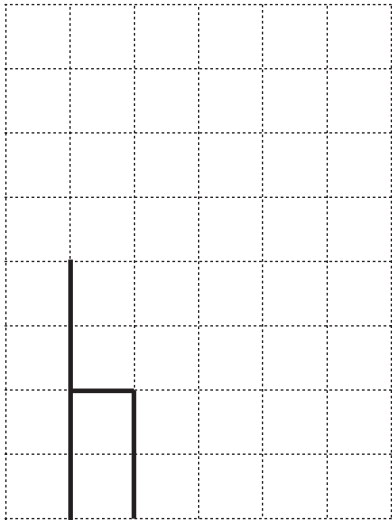

e)

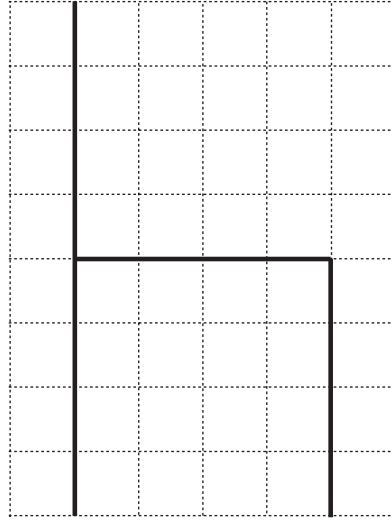

f)

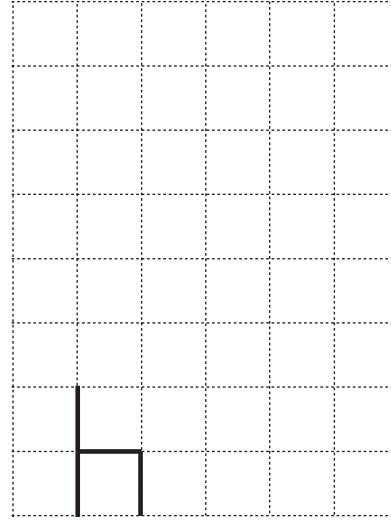

g)

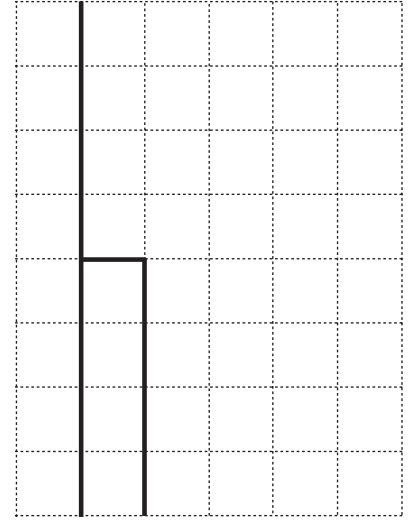

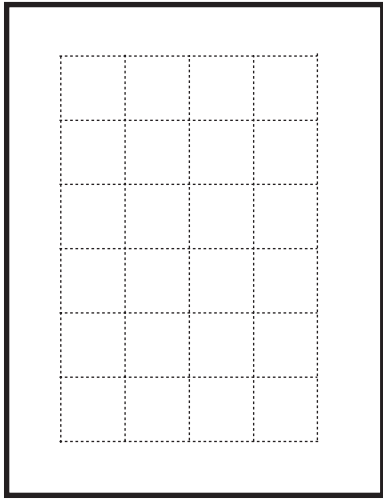

a)

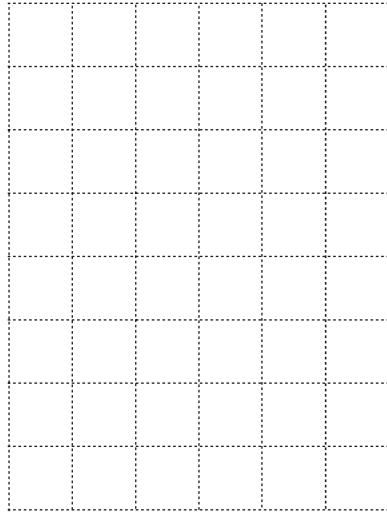

b)

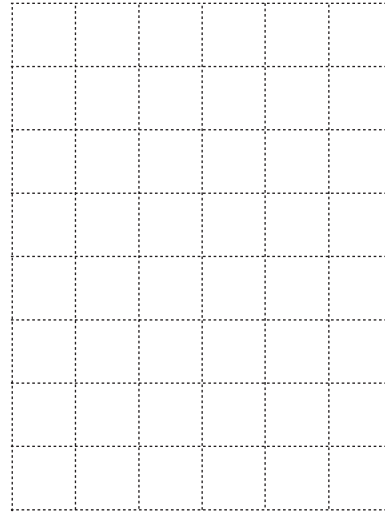

c)

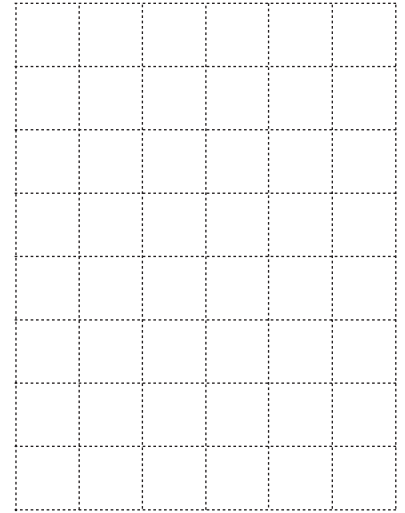

d)

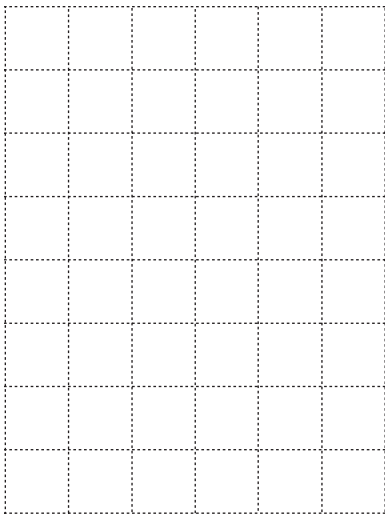

e)

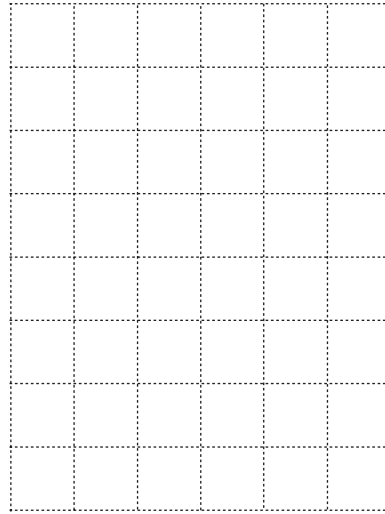

f)

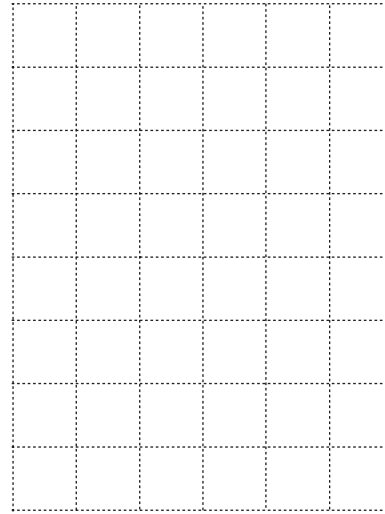

g)

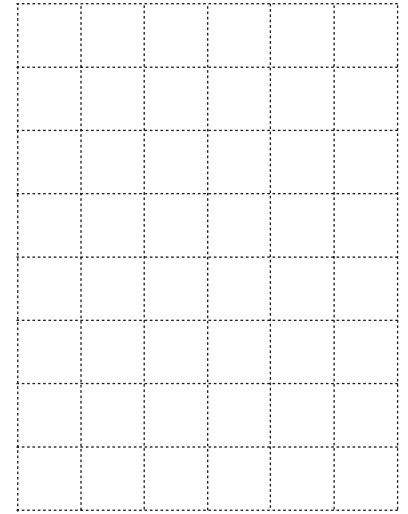

a) Top view Ground plan Front view Side view

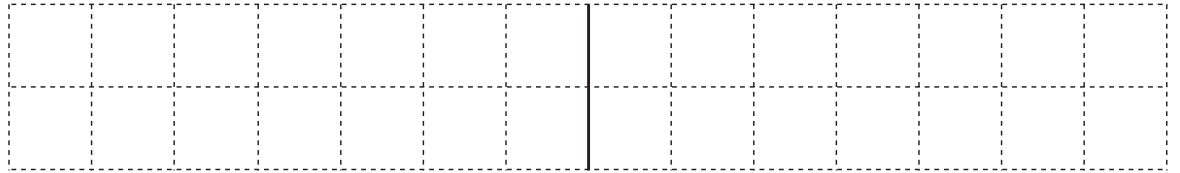
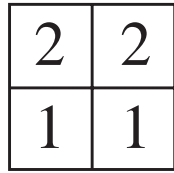
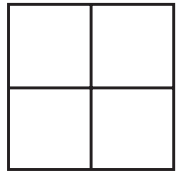

b) Top view Ground plan Front view Side view

i)

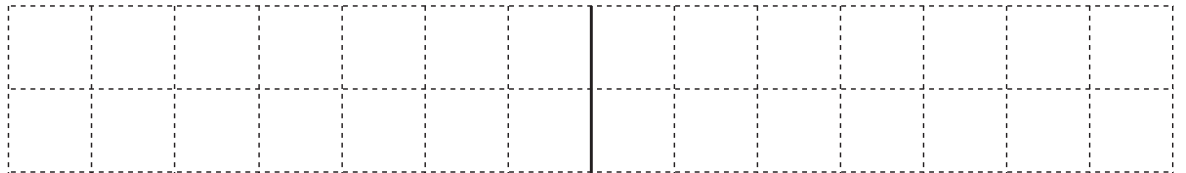
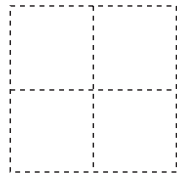
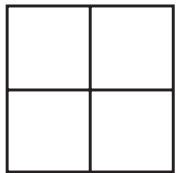

ii)

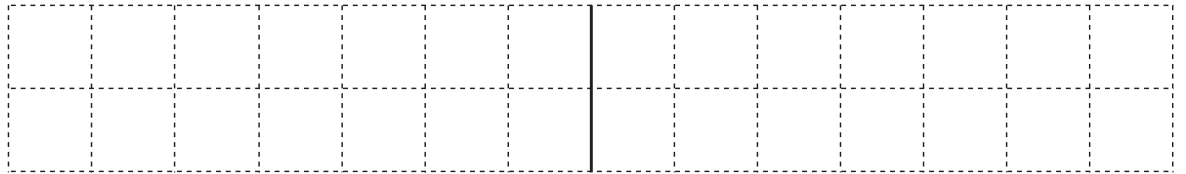
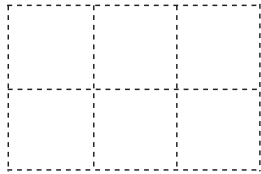
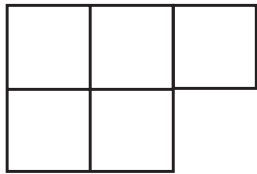

iii)

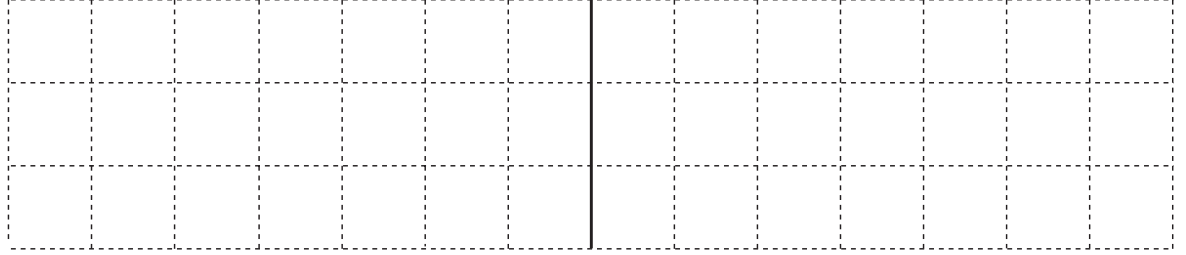
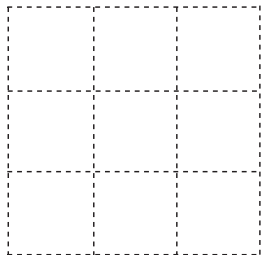
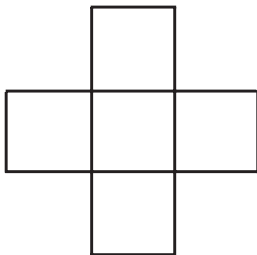

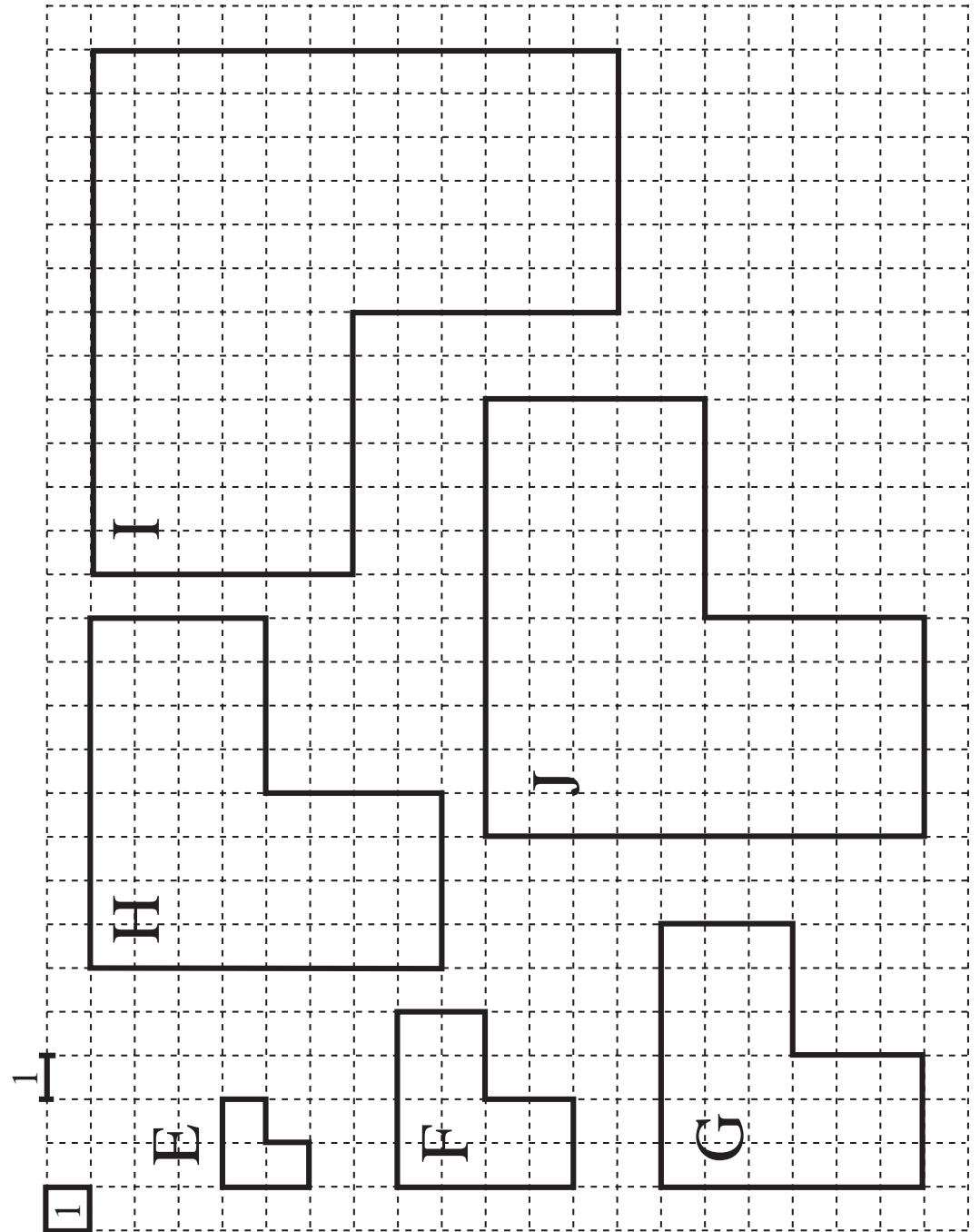
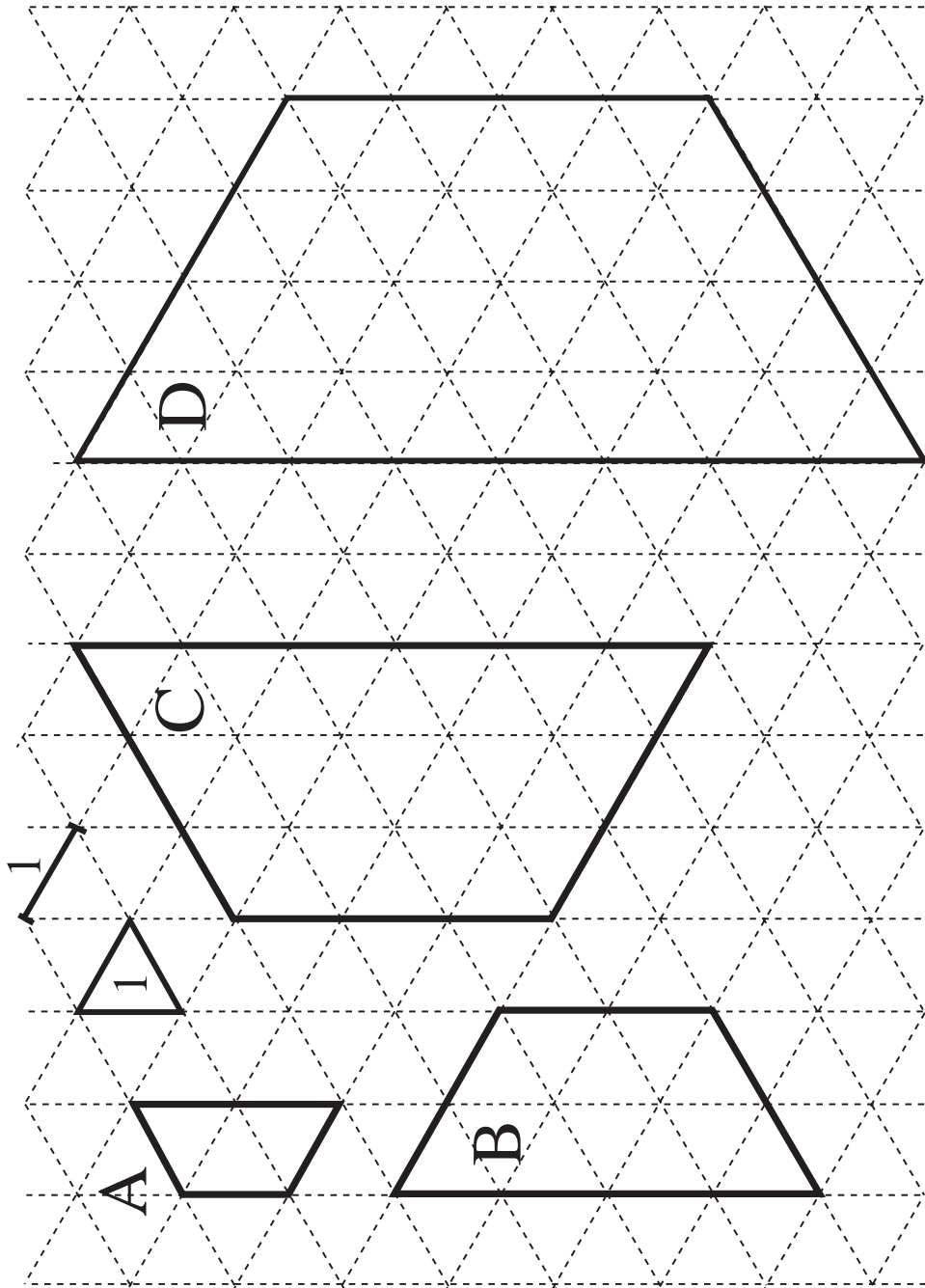

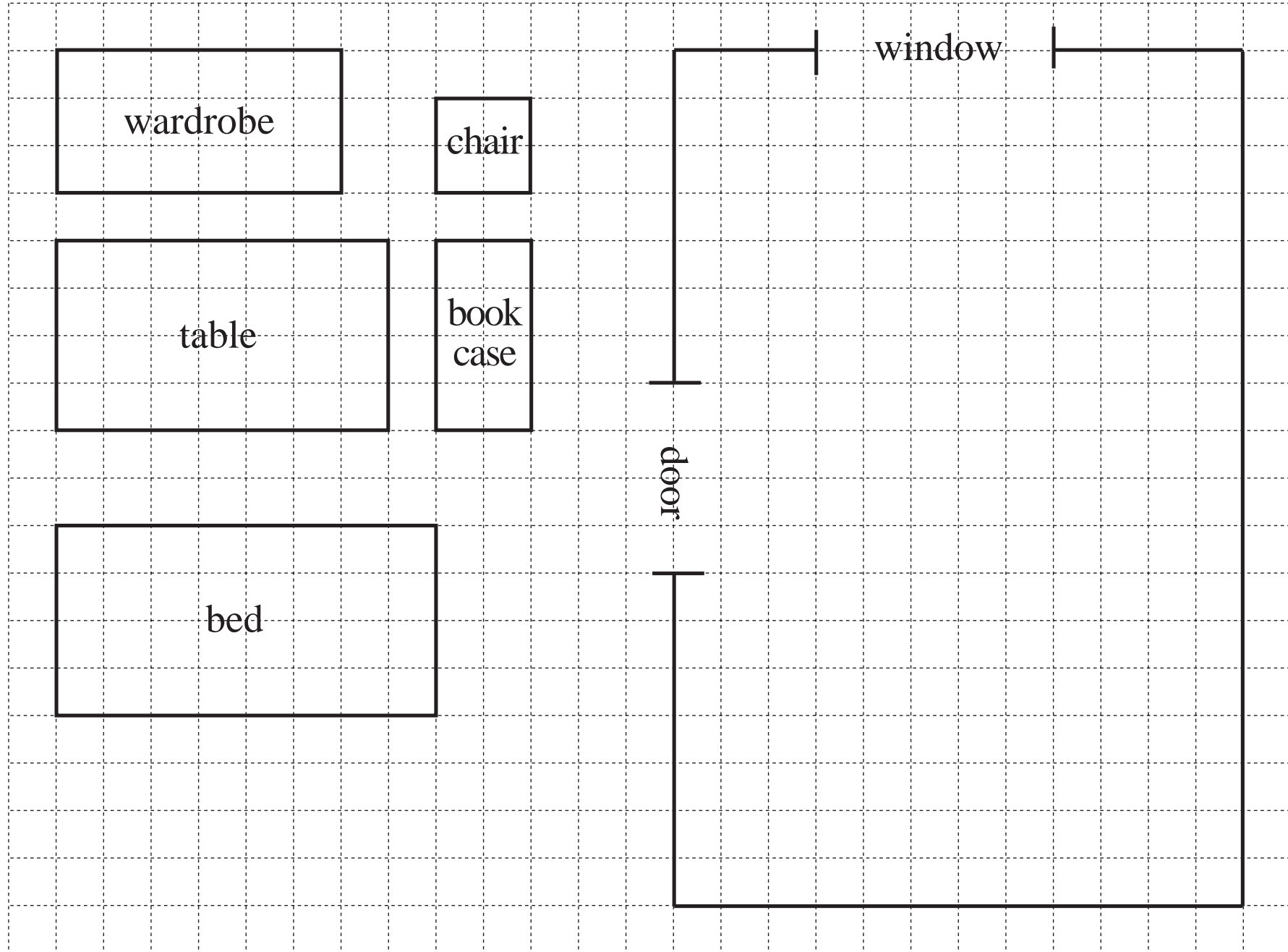

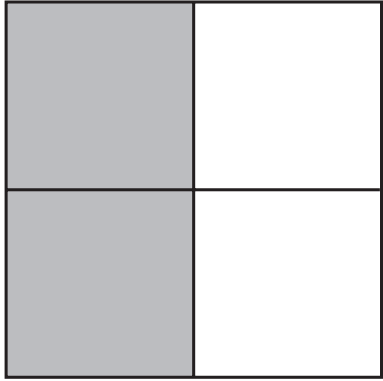

2 halves

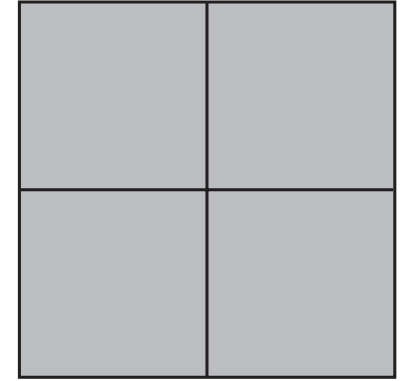

1 half

2 thirds

4 eighths

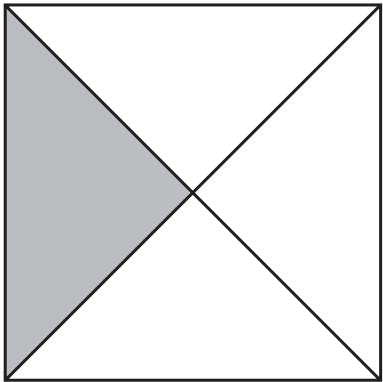

1 quarter

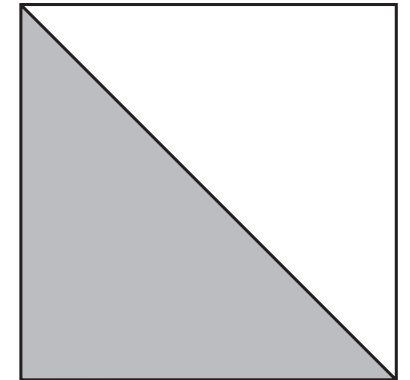
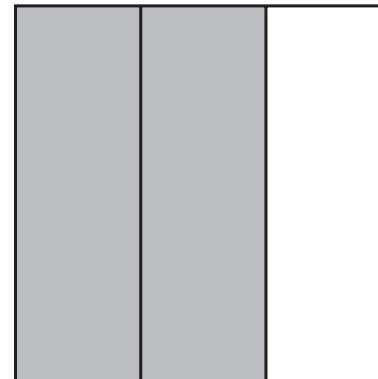
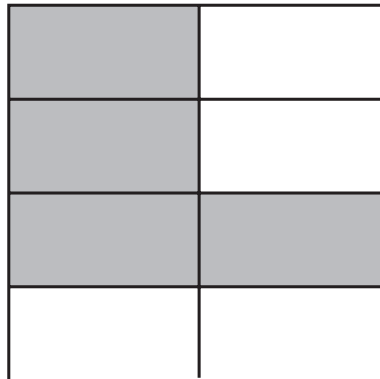

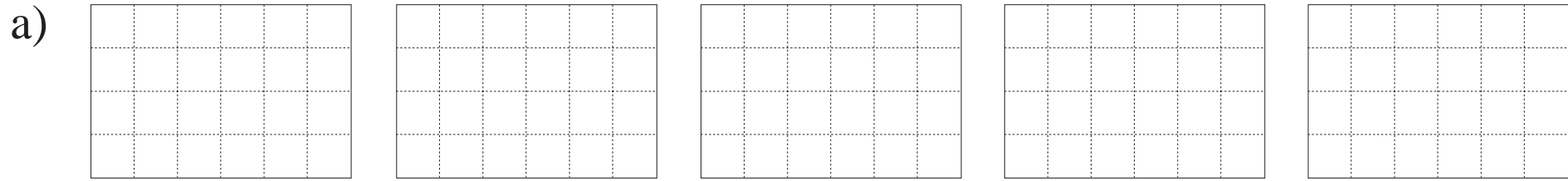

1 half

1 quarter

1 third

1 sixth

1 twelfth

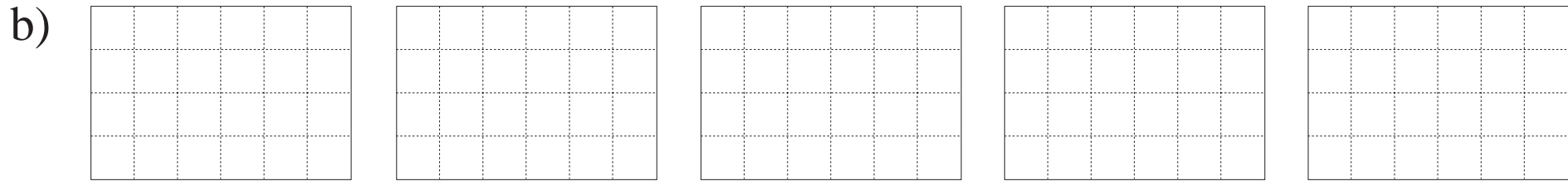

2 halves

2 quarters

2 thirds

2 sixths

2 twelfths

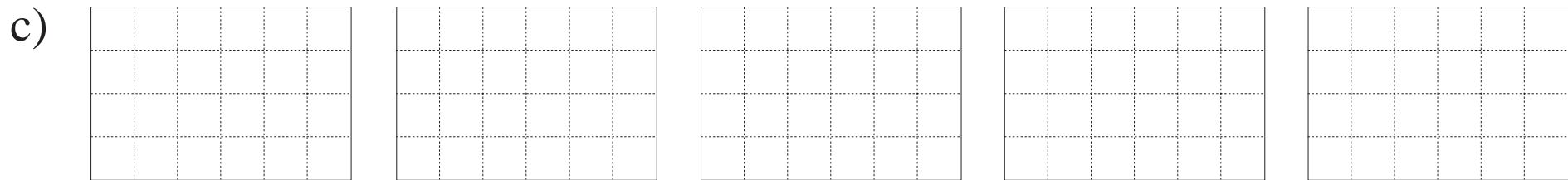

3 eighths

3 quarters

3 thirds

3 sixths

3 twelfths

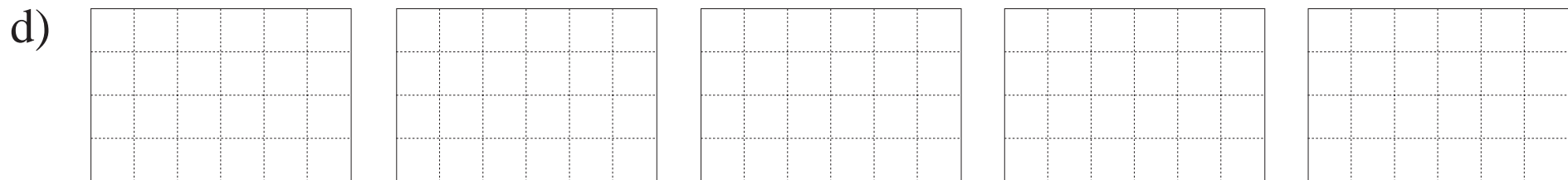

4 eighths

4 quarters

4 twelfths

6 sixths

6 twelfths

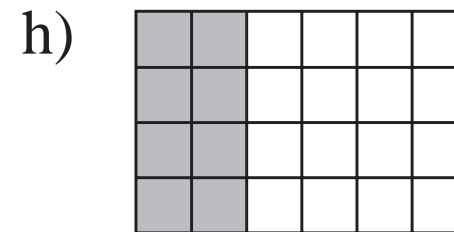
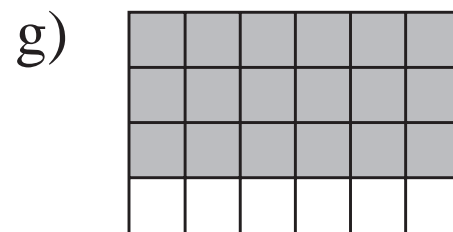
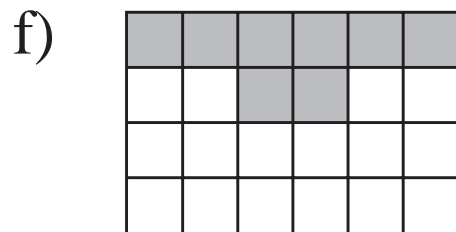
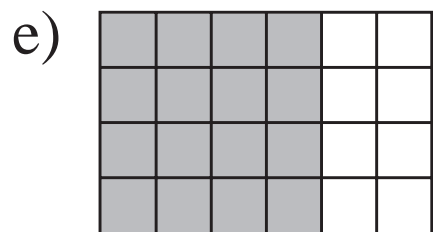
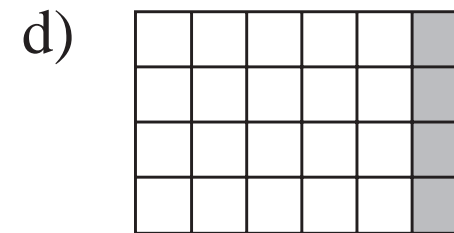
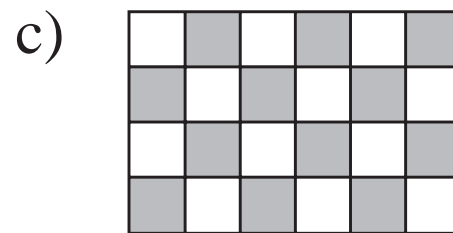
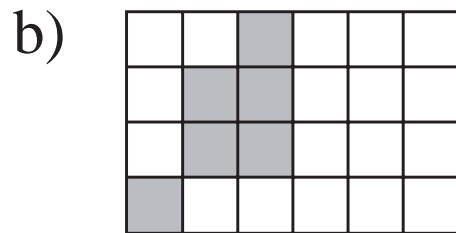
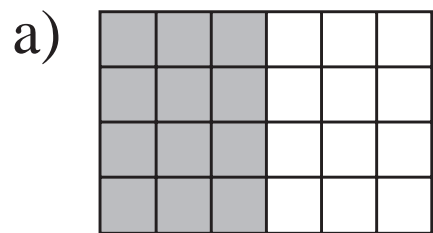

LP 121/5

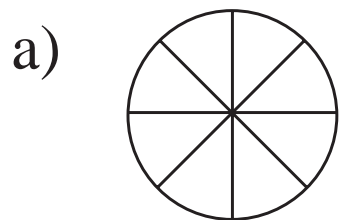

4 eighths

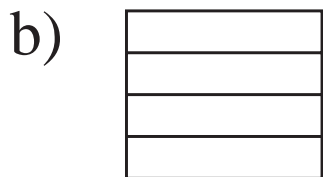

3 quarters

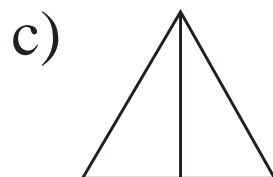

1 half

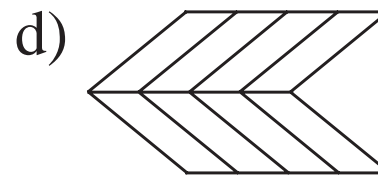

3 eighths

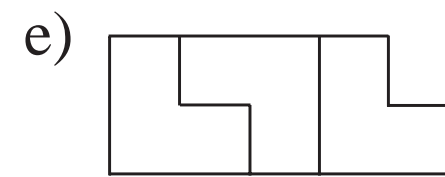

1 third

1 unit

a)



b)



c)

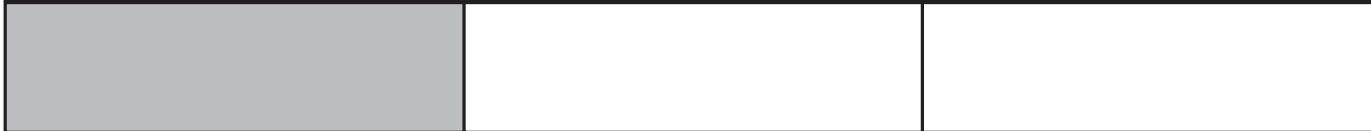

d)



e)



f)



g)

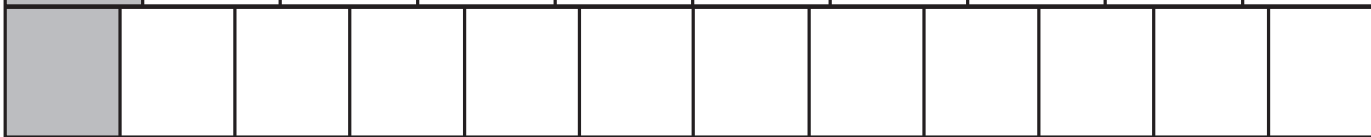

.....

.....

.....

.....

.....

.....

.....



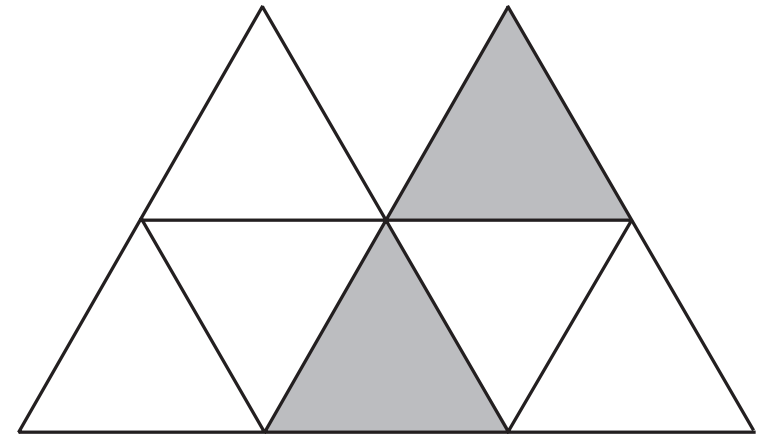
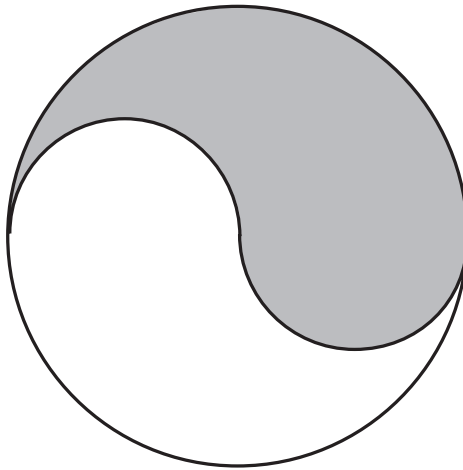
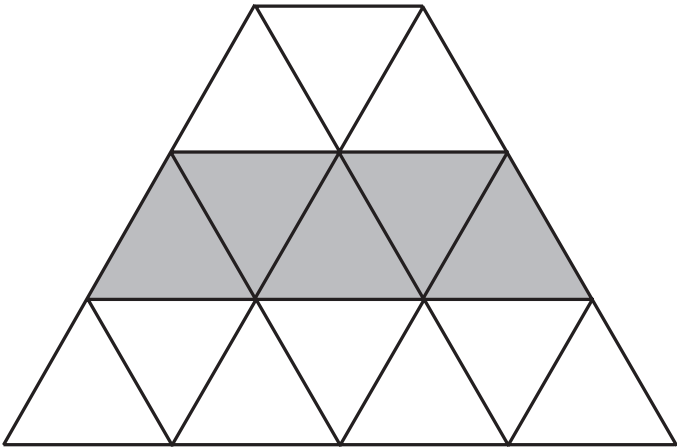
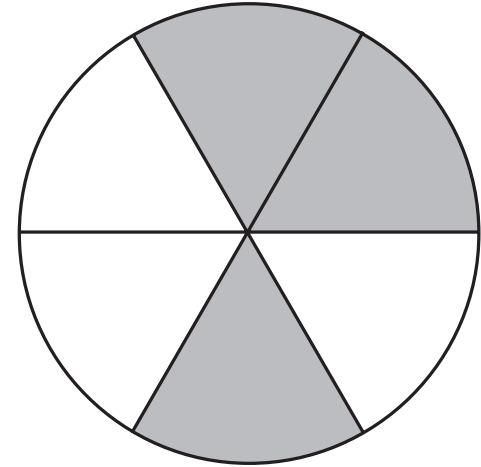
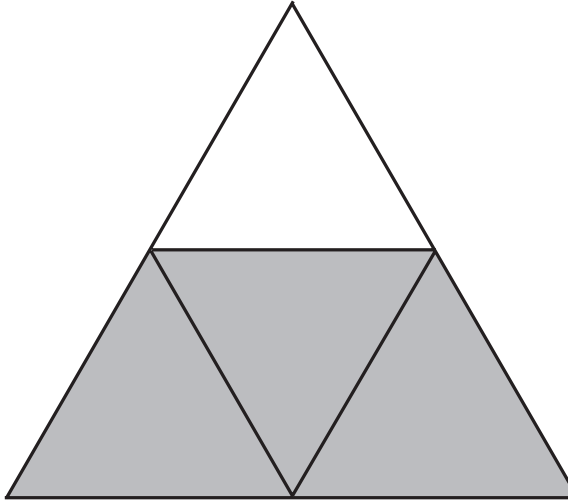
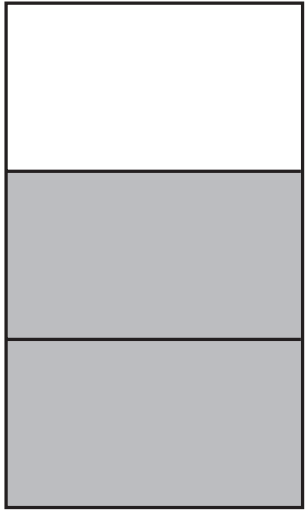

a)

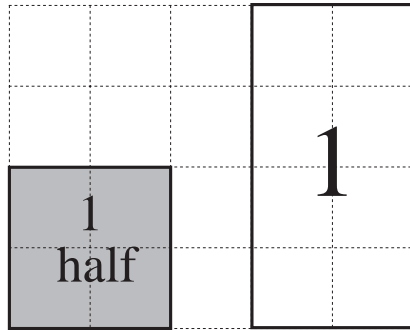

b)

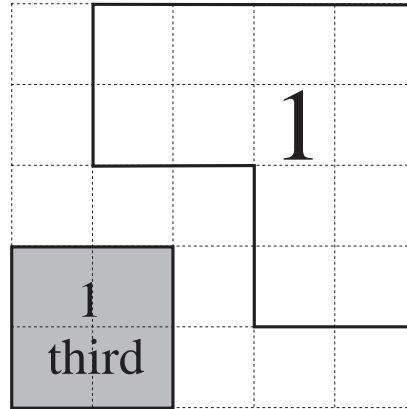

c)

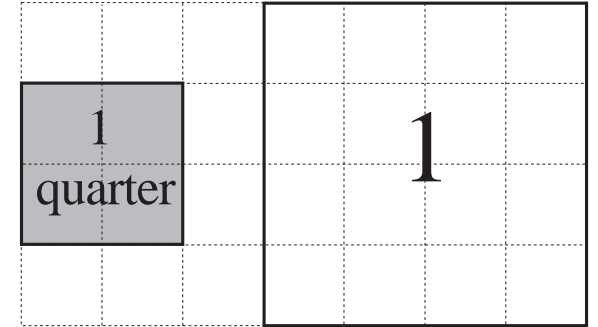

d)

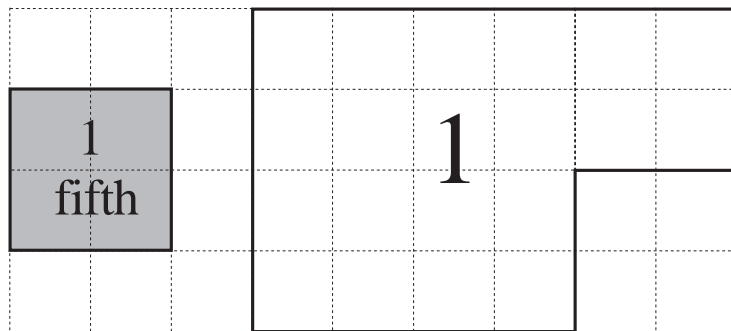

e)

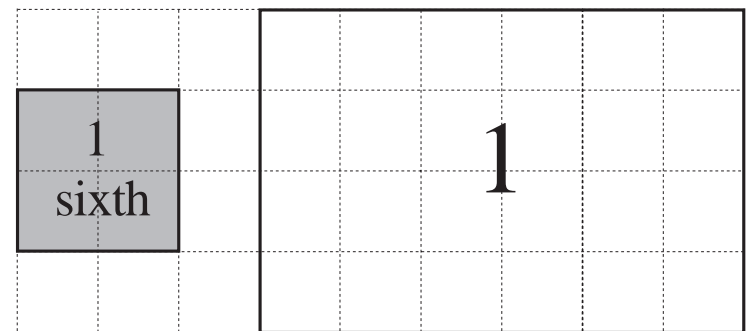

1 unit

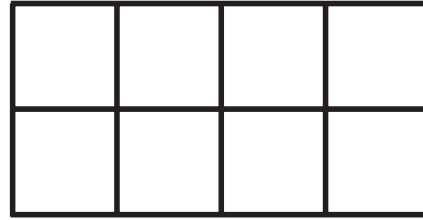

a)



b)



c)



d)

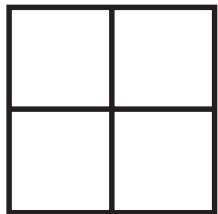

e)

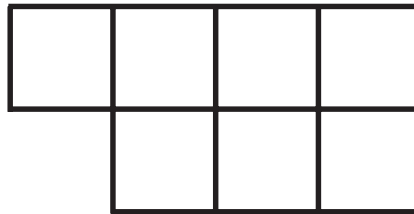

f)

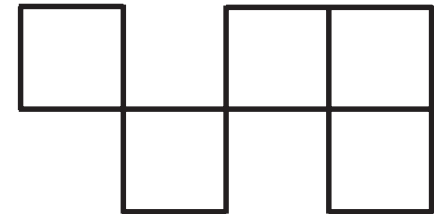

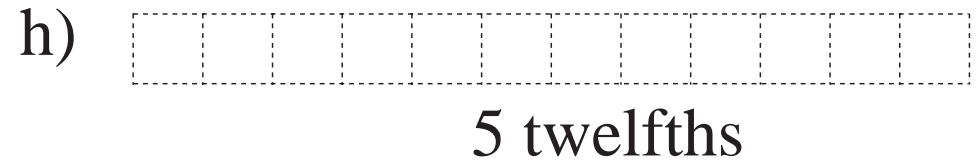
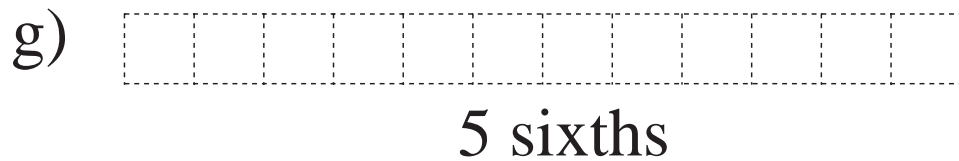
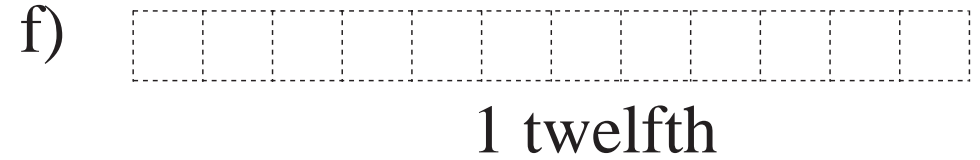
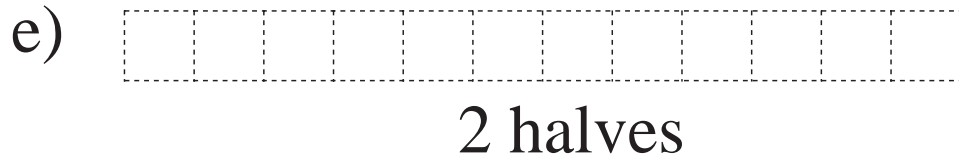
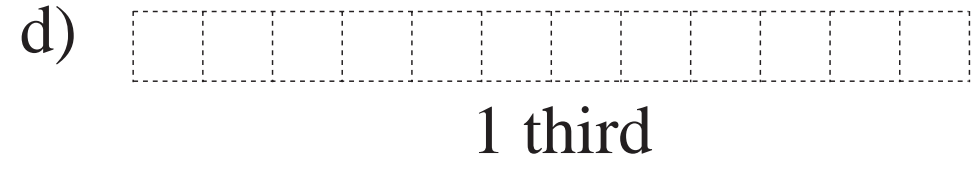
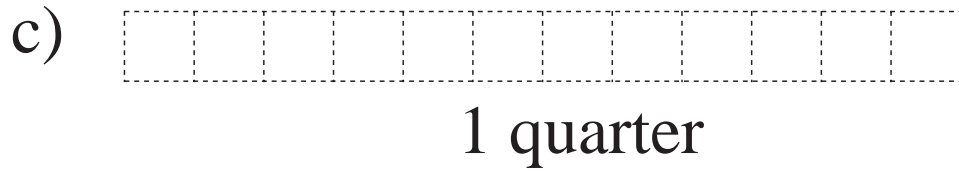
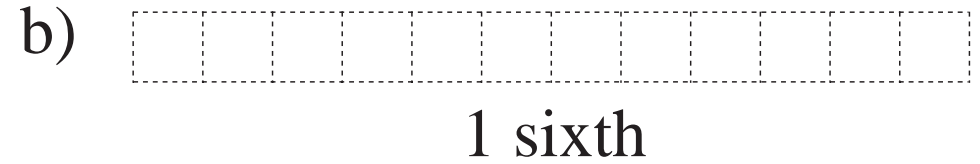
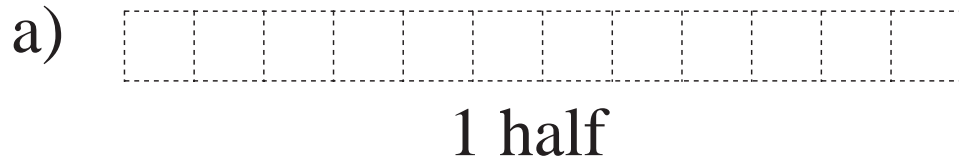

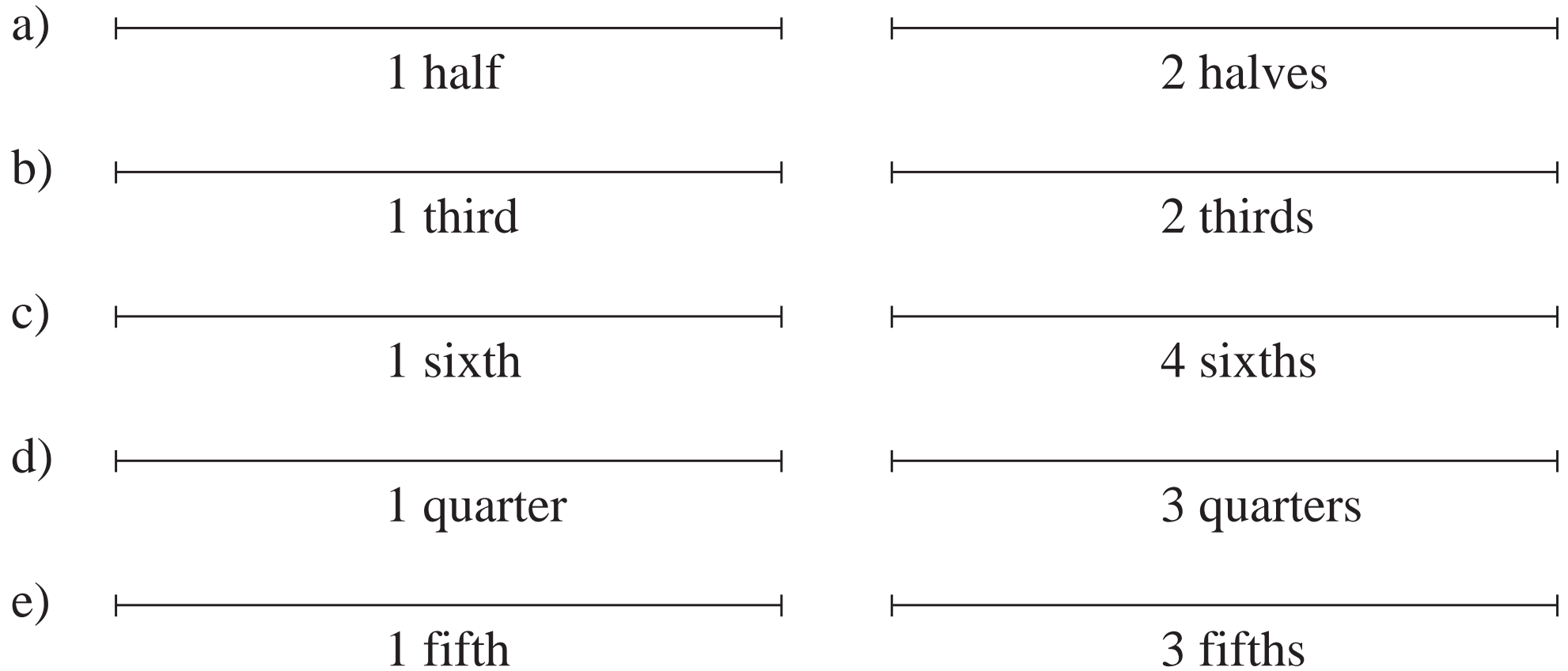

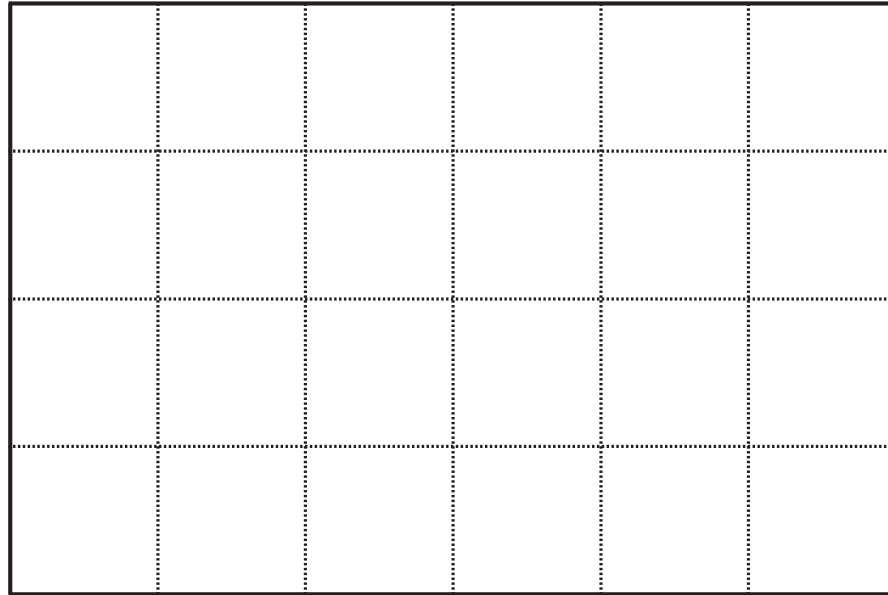
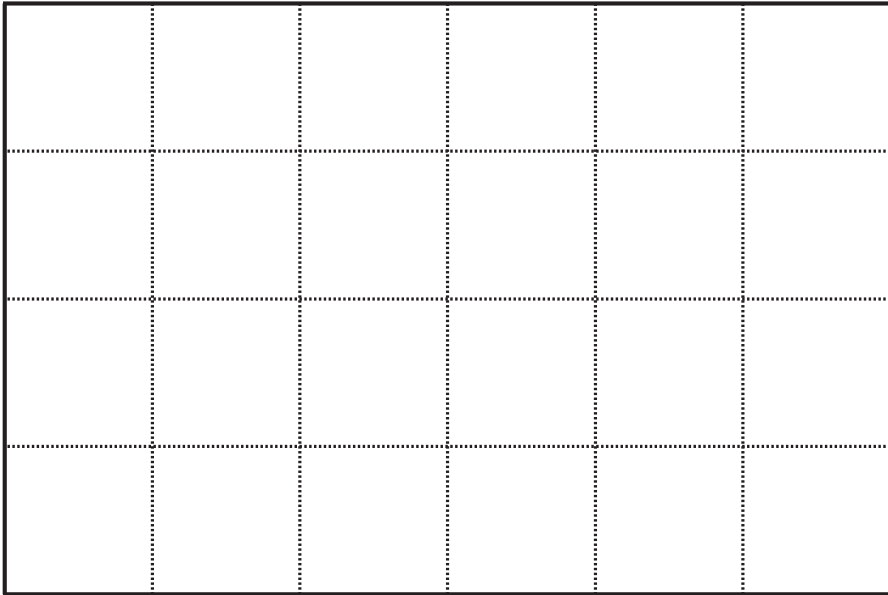
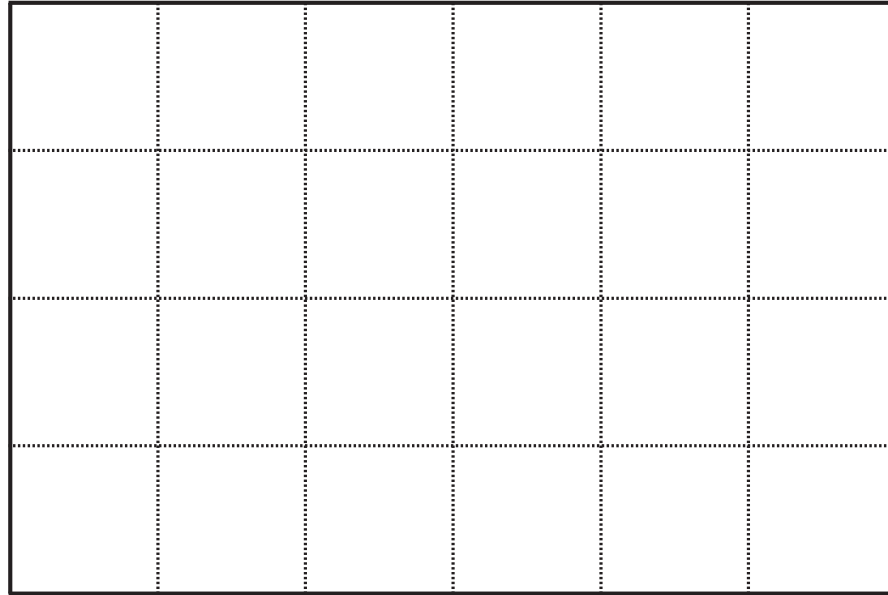
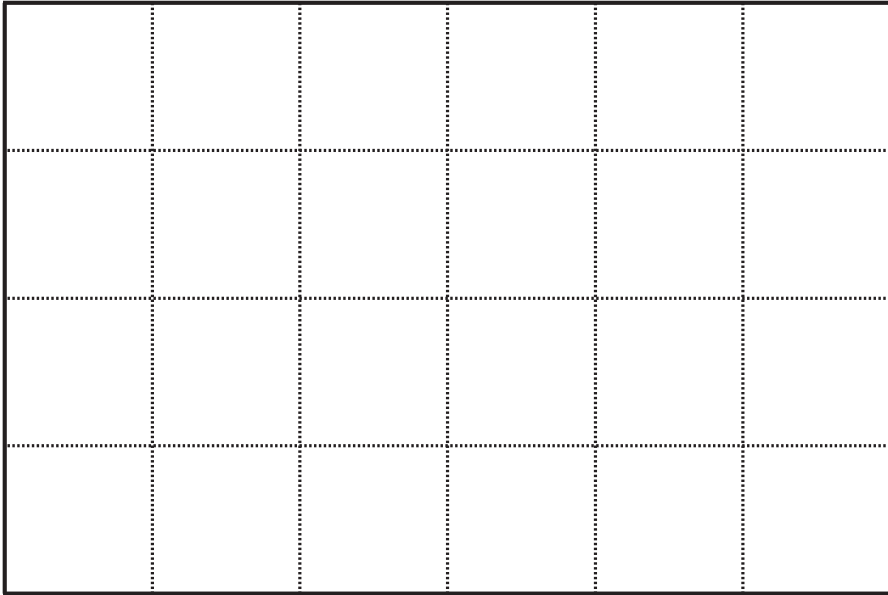

a)

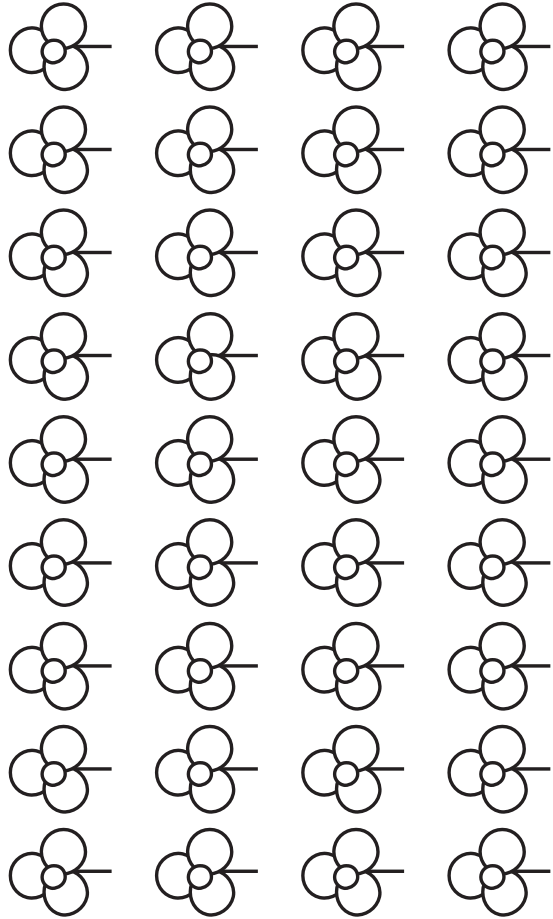

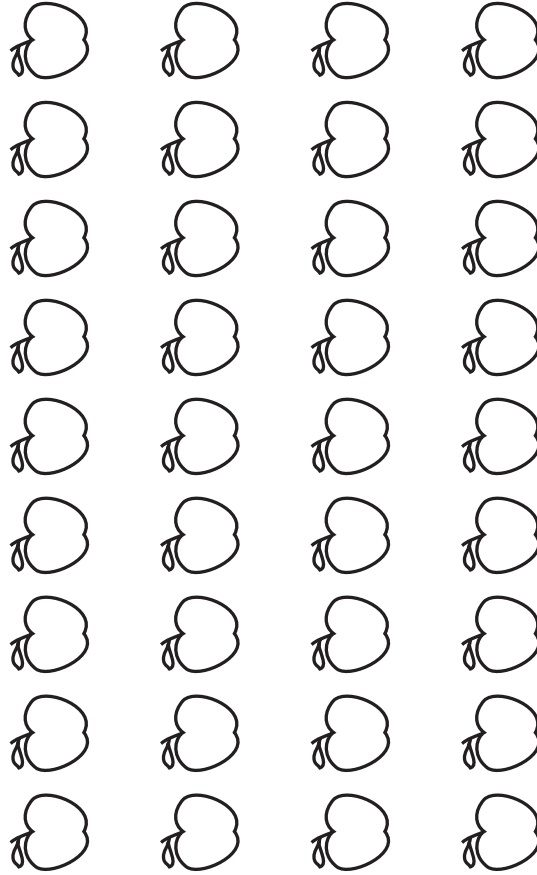

b)



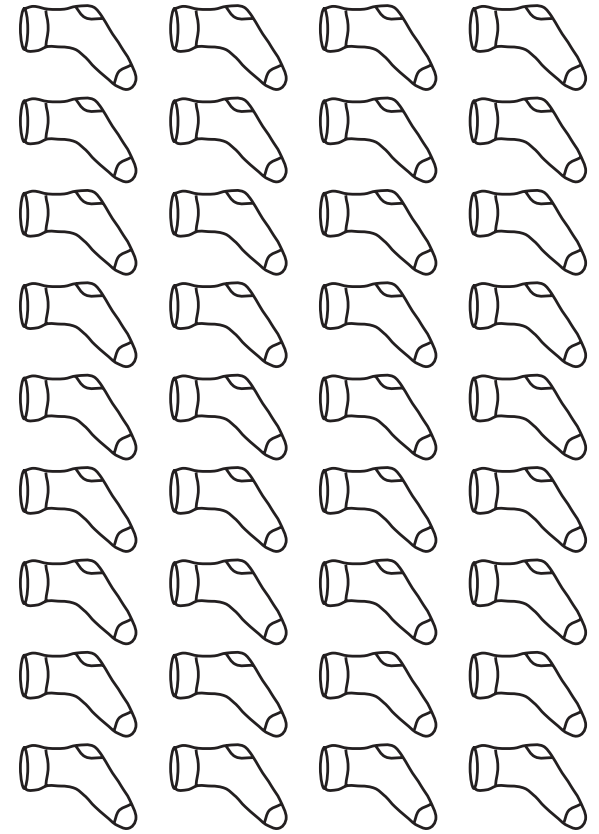

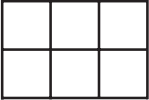
c)

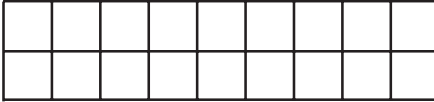

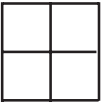

a)   

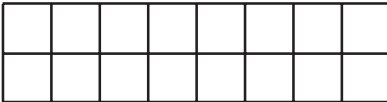
half halves halves

b)    

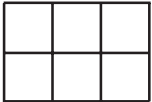
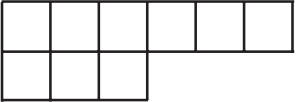
third thirds thirds thirds

c)     

quarter quarters quarters quarters quarters

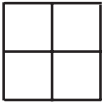
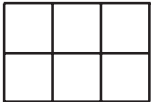
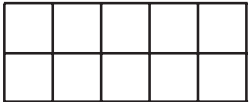
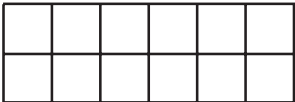
d)     

sixth sixths sixths sixths sixths

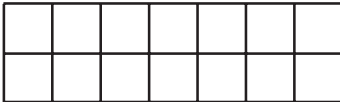
 sixths

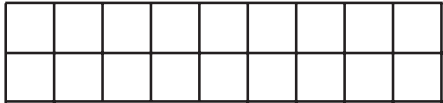
 sixths

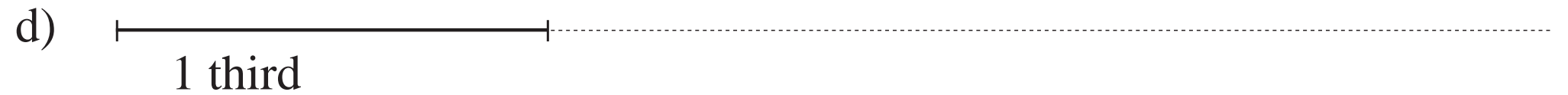
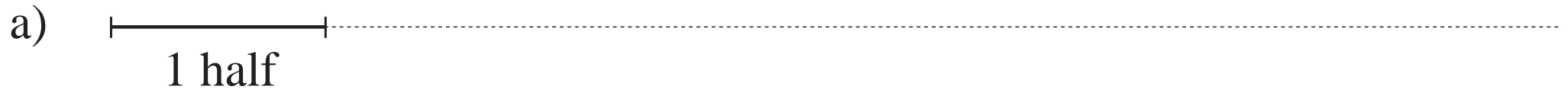

a)

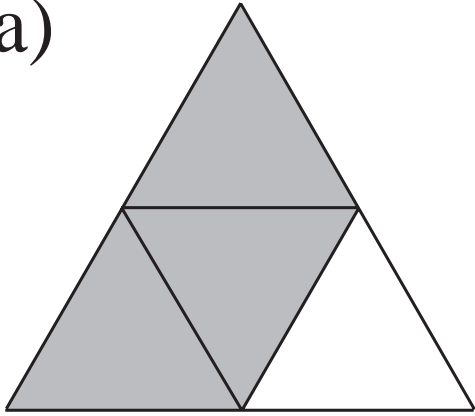

1 half

b)

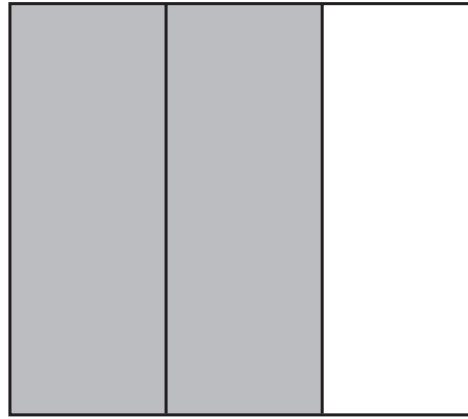

2 thirds

c)

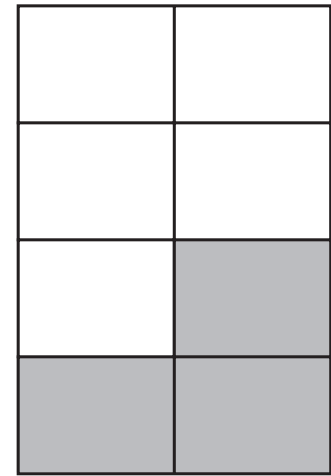

3 eighths

d)

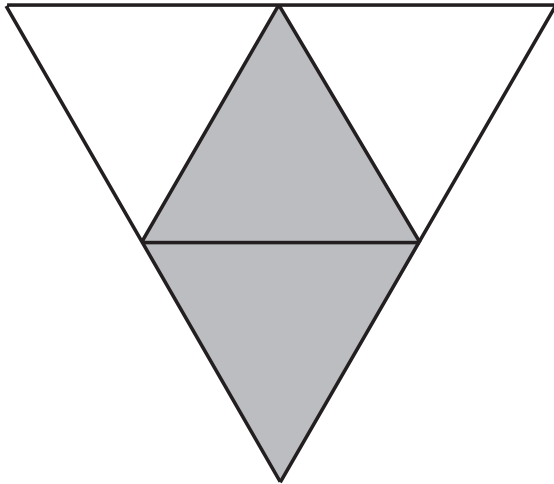

2 quarters

e)

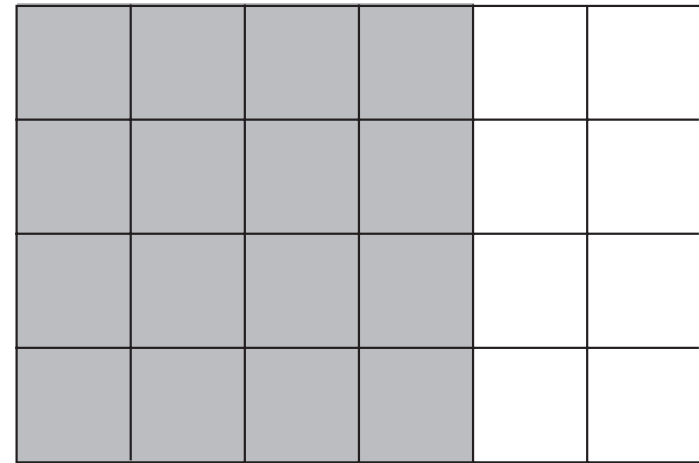

3 quarters

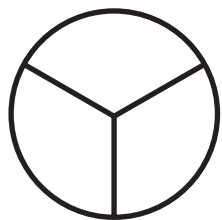

1

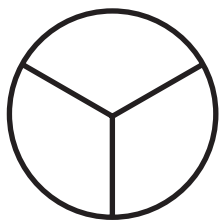

2

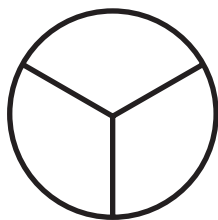

3

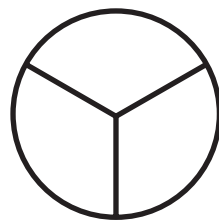

4

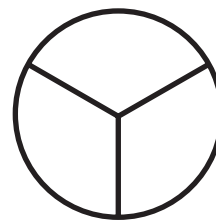

5

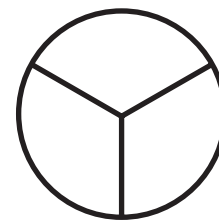

6

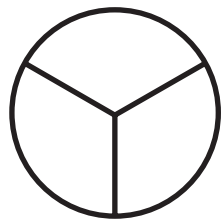

7

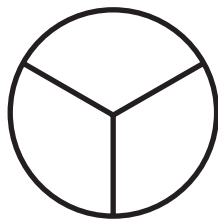

8

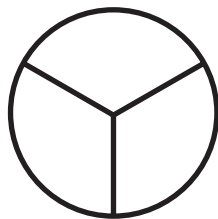

9

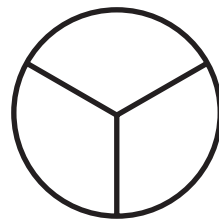

10

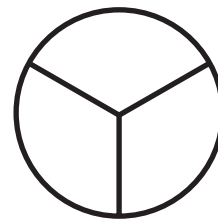

11

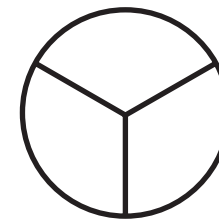

12

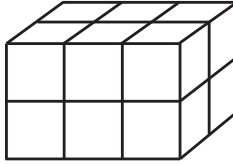
1 unit = 

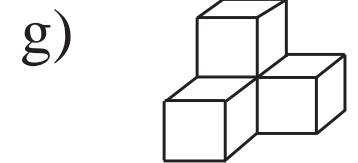
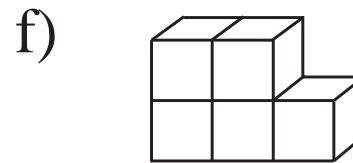
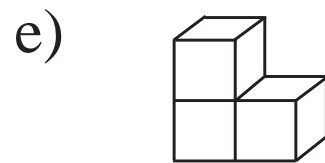
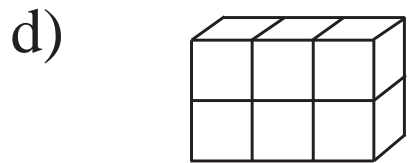
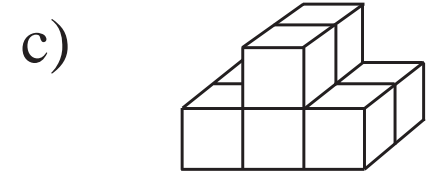
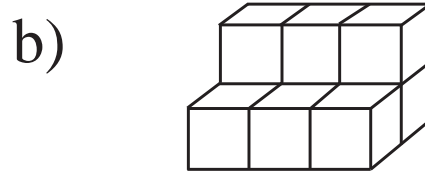
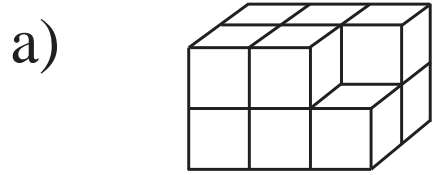

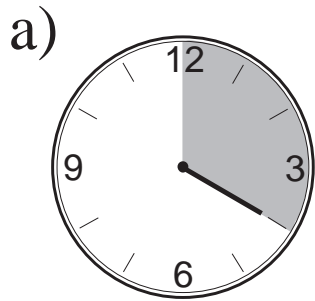

20 minutes

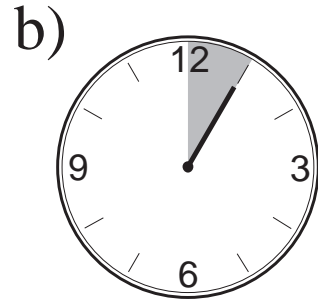

5 minutes

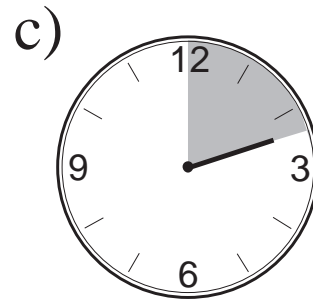

12 minutes

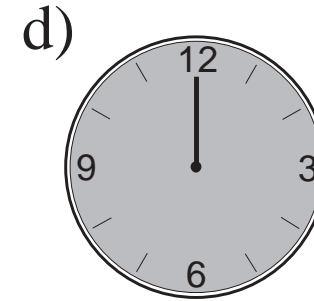

60 minutes

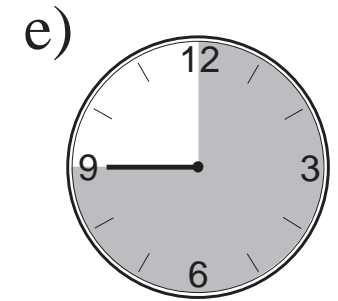

45 minutes

hour

hour

hour

hour

hour

LP 124/7

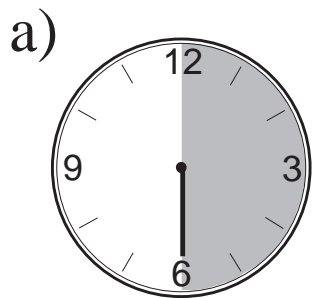

half an hour

min.

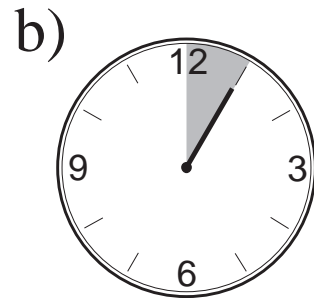

1 twelfth
of an hour

min.

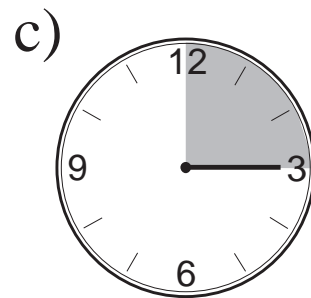

1 quarter
of an hour

min.

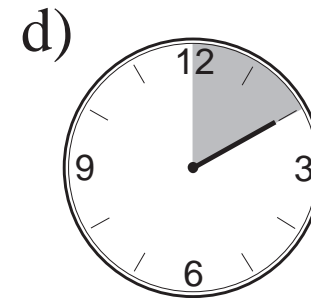

1 sixth
of an hour

min.

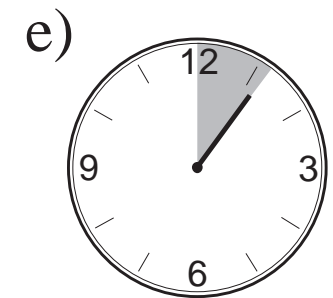

1 tenth
of an hour

min.

a) half a metre = cm

1 fifth of a metre = cm

1 tenth of a metre = cm

3 quarters of a metre = cm

3 fifths of a metre = cm

7 tenths of a metre = cm

11 hundredths of a metre = cm

b) half a kg = g

1 quarter of a kg = g

1 tenth of a kg = g

3 quarters of a kg = g

5 tenths of a kg = g

2 fifths of a kg = g

9 hundredths of a kg = g

a) $349 + 572 < 727$ 199

C:

	3	4	9
+	5	7	2

b) $942 - 443 > 849$ 367

C:

0, 4, 13, 30, 72, 95, 100, 321, 679, 1000, 1006, 1027, 2000

a)

Even	Odd

b)

Whole tens	Not whole tens

c)

3-digit	Not 3-digit

d)

Whole hundreds	Not whole hundreds

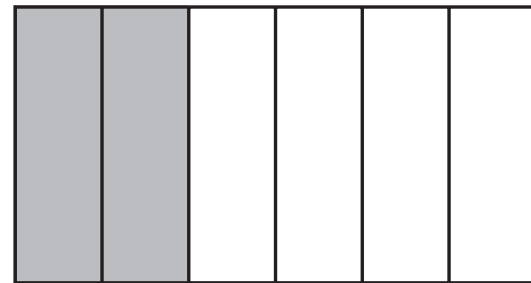
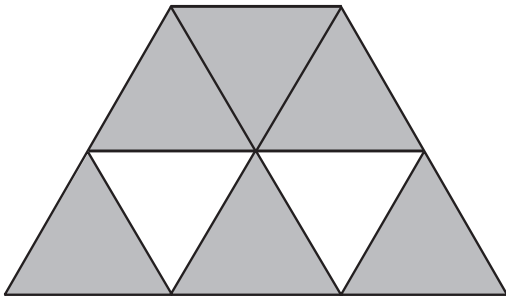
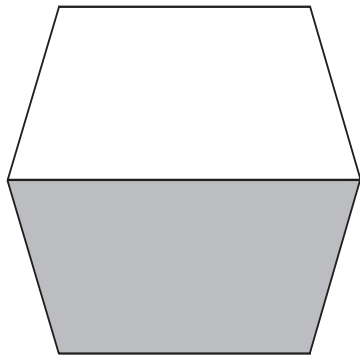
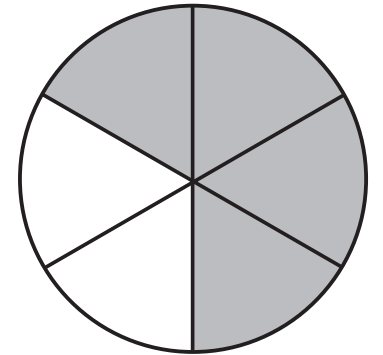
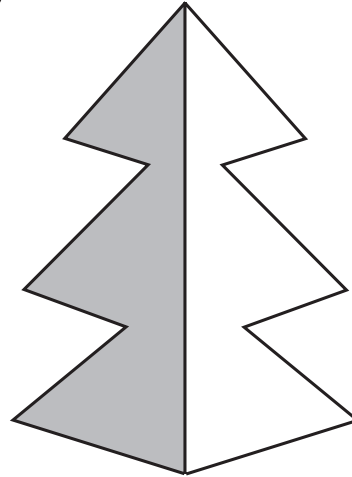
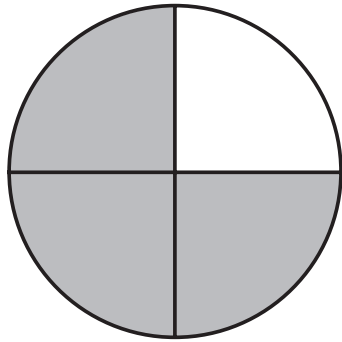
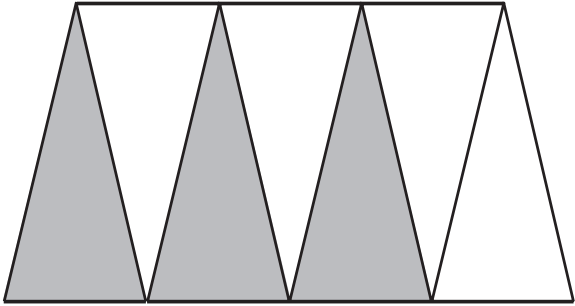

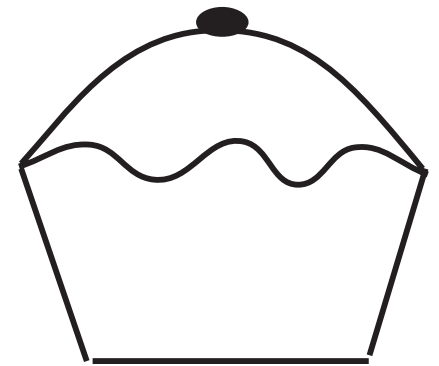
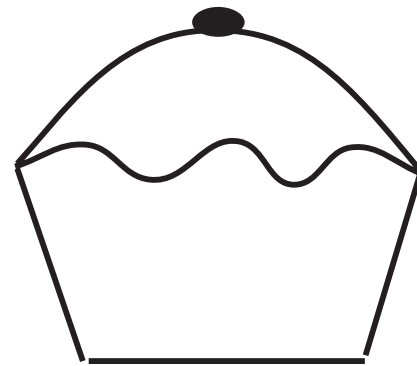
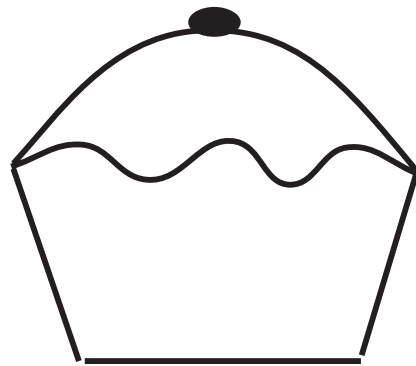
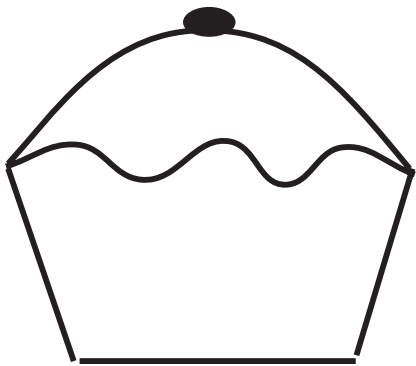
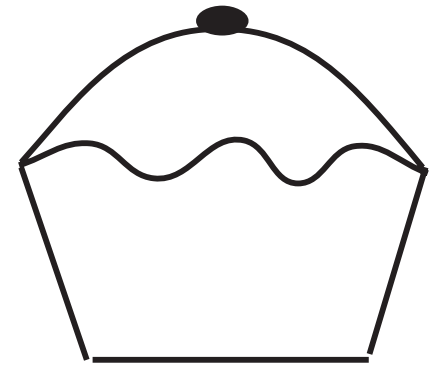
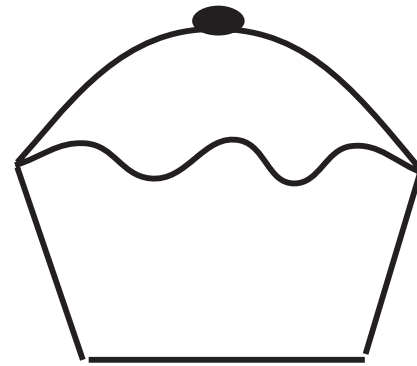
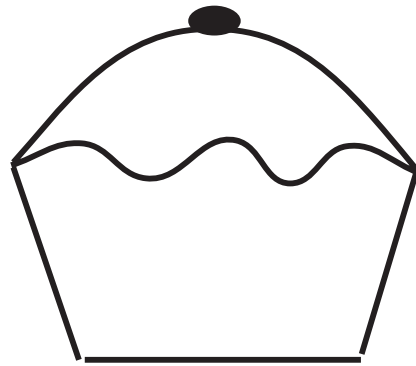
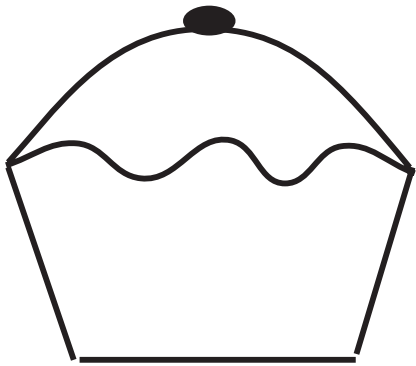
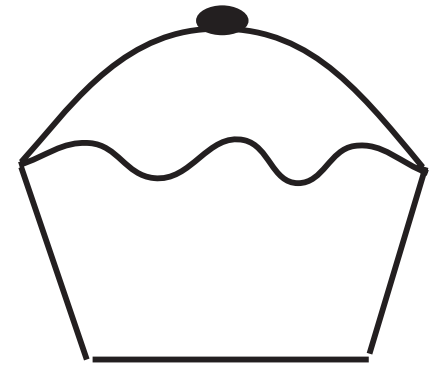
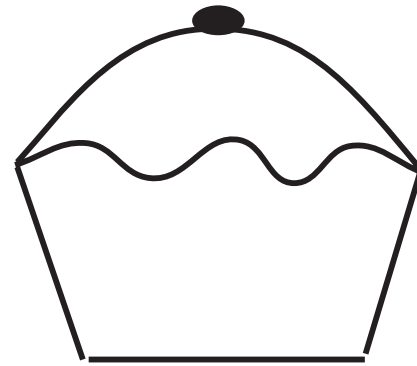
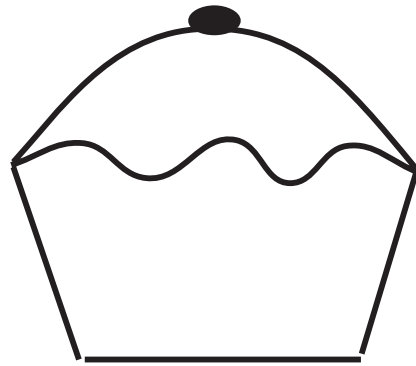
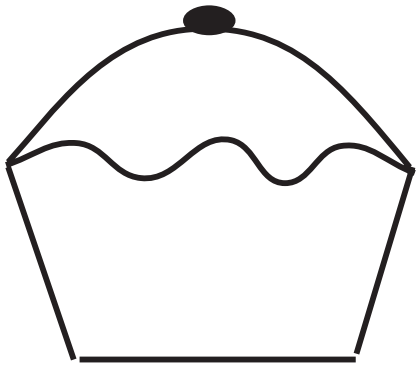

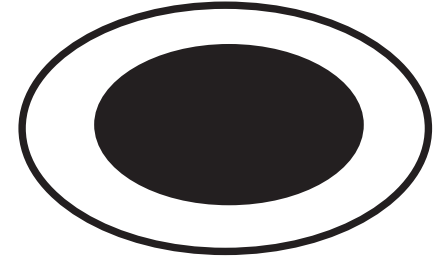
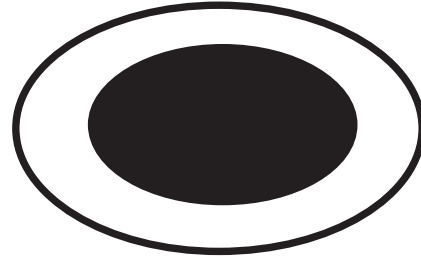
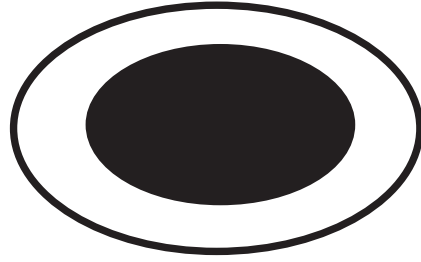
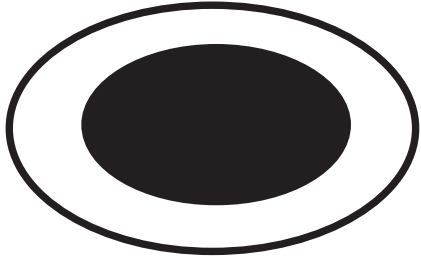
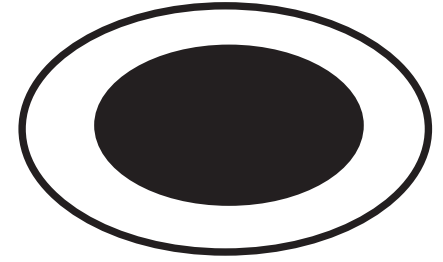
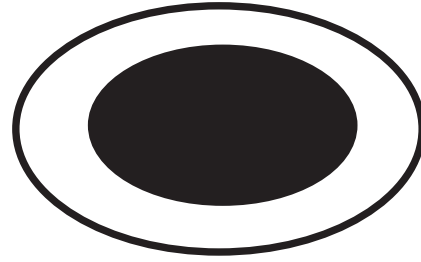
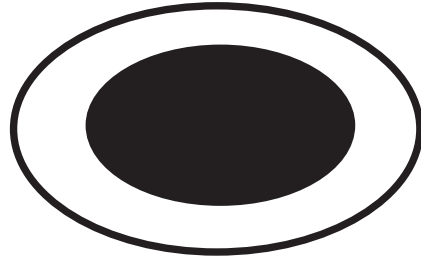
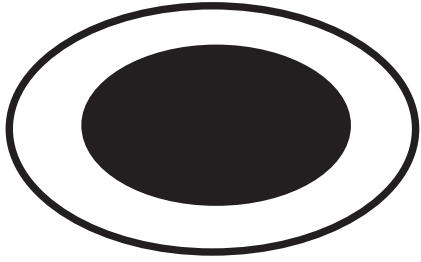
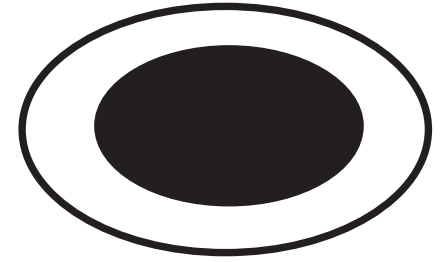
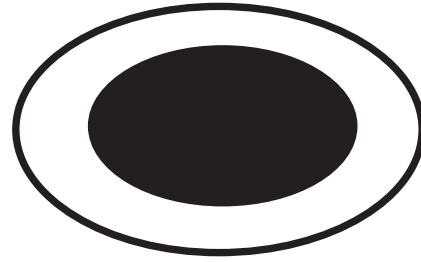
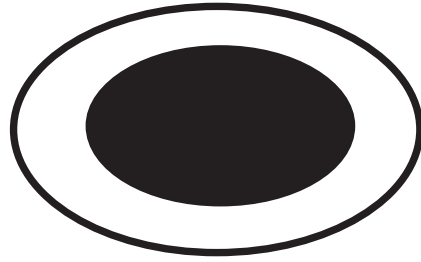
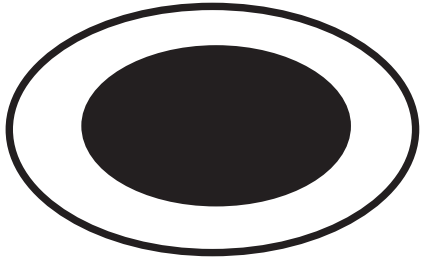
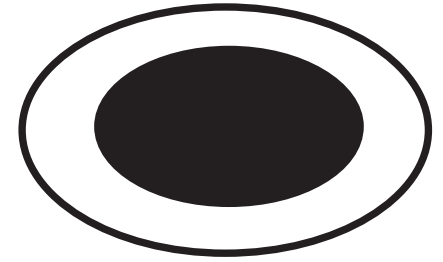
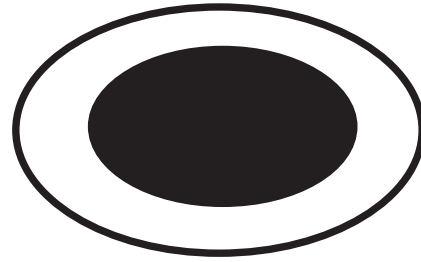
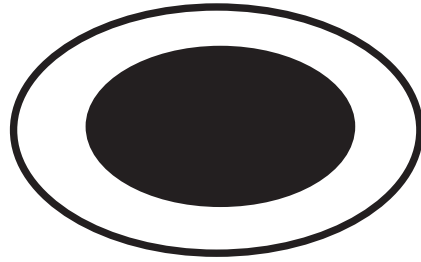
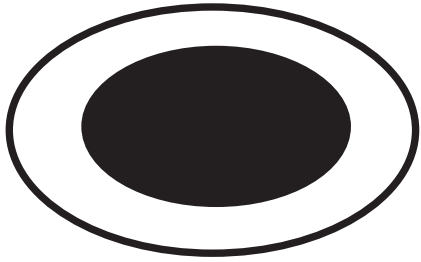

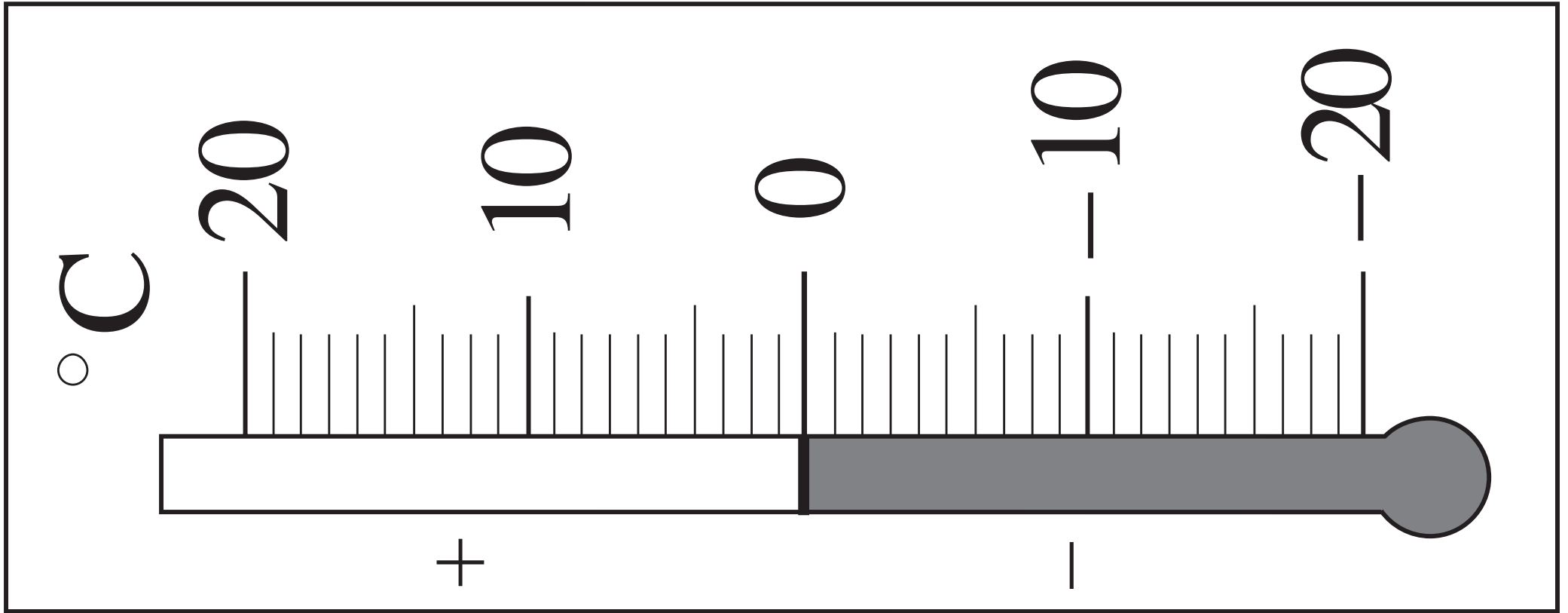

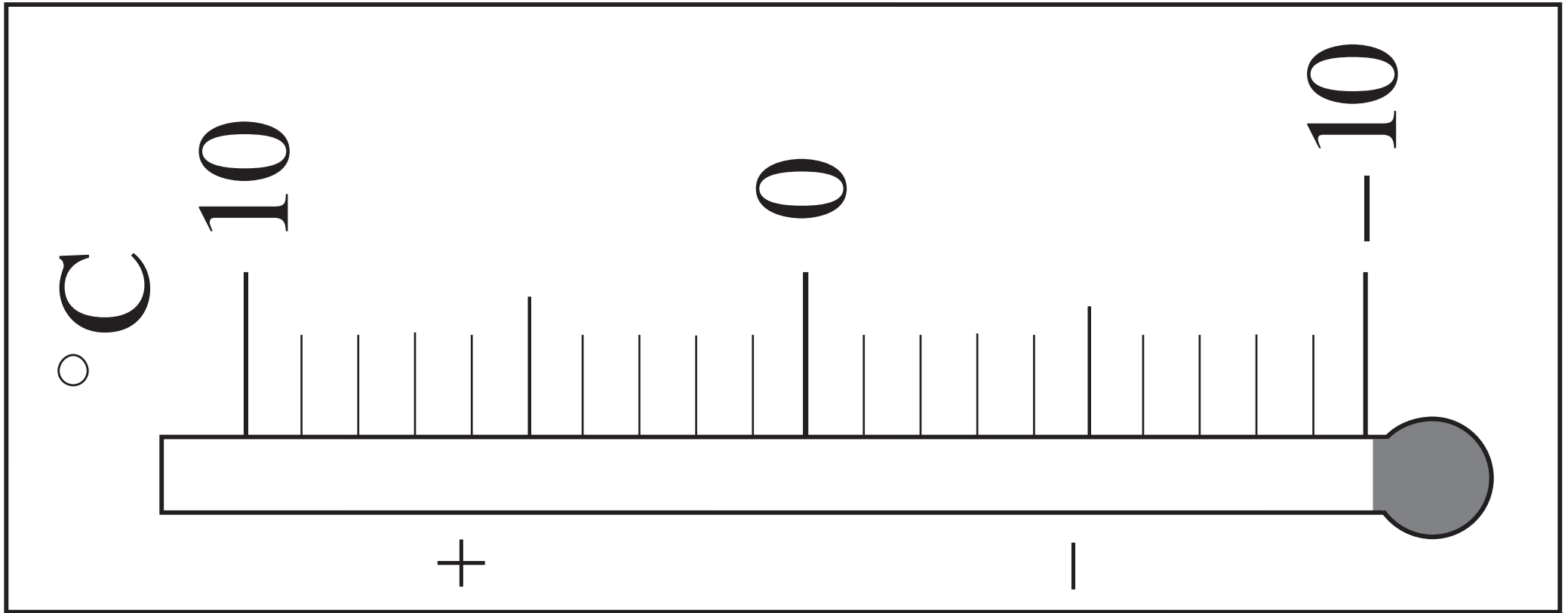

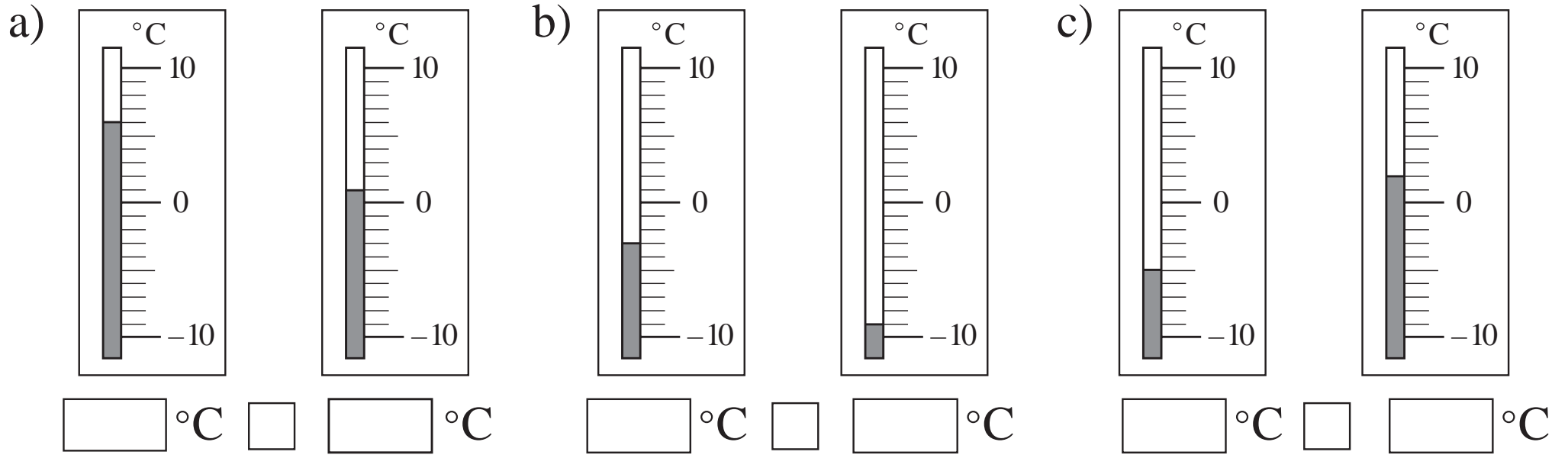

LP 128/3

B.C.

A.D.



LP 128/5

a)

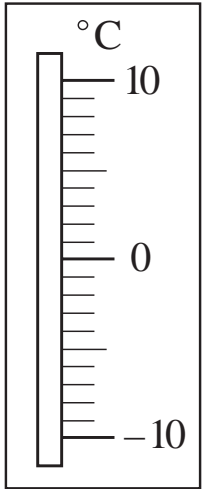

5 °C

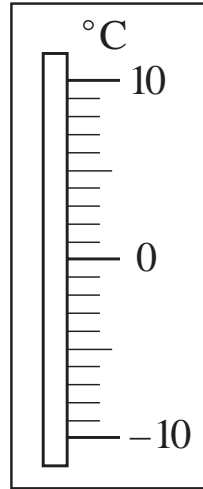

-5 °C

 °C

b)

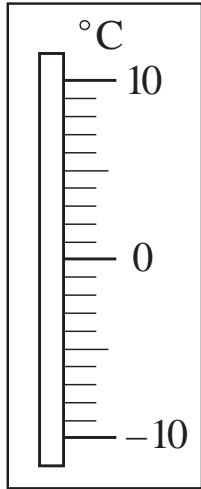

-9 °C

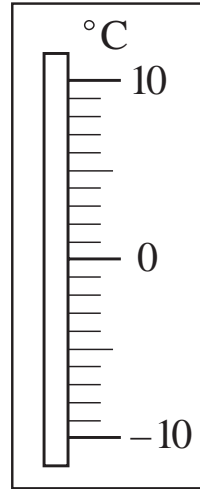

0 °C

 °C

c)

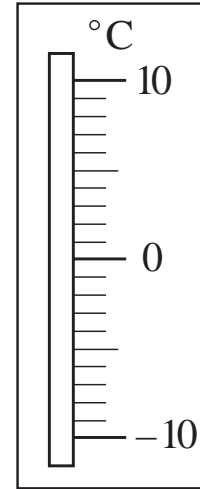

-1 °C

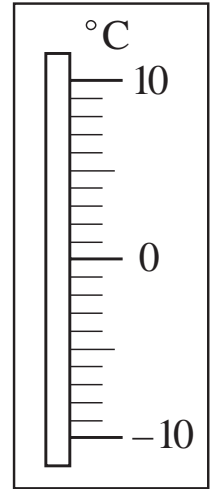

-10 °C

 °C

LP 128/6

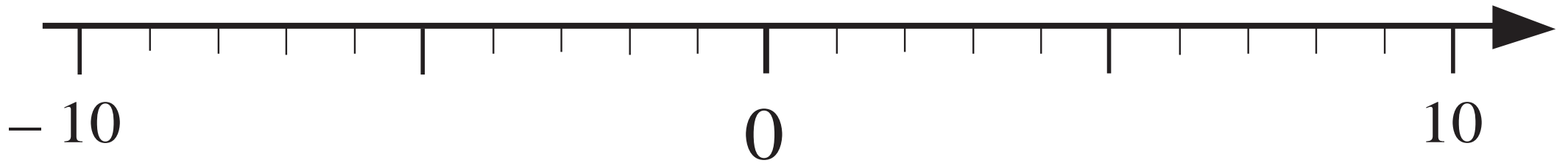

a) Ann

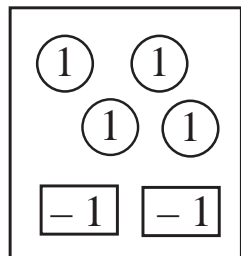

Paul

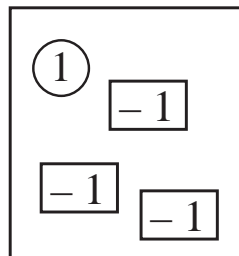

b) Ben

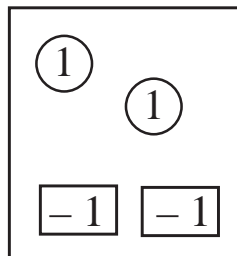

Rose

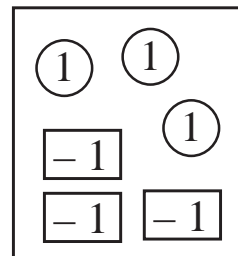

c) Colin

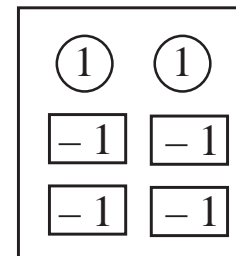

Sonia

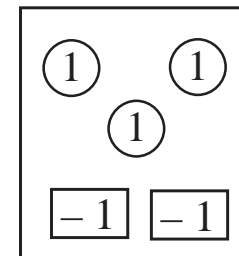

LP 128/8

 a) Alice's balance is $-\pounds 6$: $(1) (1) [-1] [-1] [-1] [-1] [-1] [-1]$

 b) Barry's balance is $\pounds 3$: $(1) (1) (1) [-1] [-1]$

 c) Carol's balance is $\pounds 0$: $(1) (1) (1) (1) [-1] [-1] [-1] [-1]$

 d) Dan's balance is $-\pounds 4$: $(1) (1) (1)$

 e) Eve's balance is $\pounds 5$: $(1) (1) (1) (1) (1) (1)$

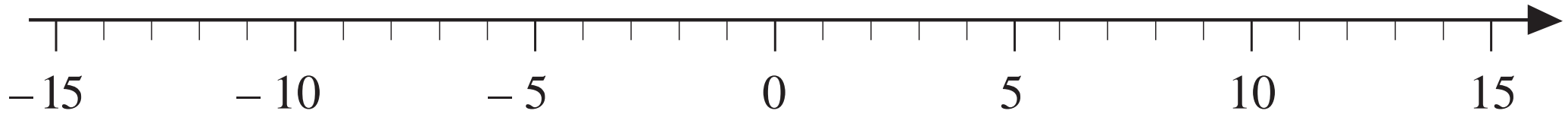
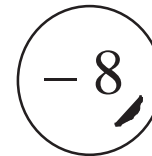
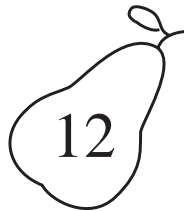
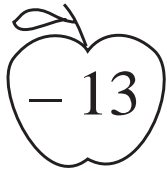

LP 129/3

Time (hours)	7	8	9	10	11	12	13	14	15	16	17	18	19
Temperature (°C)	-9	-10	-6	-2	0	3	6	8	9	7	4	-1	-3

LP 129/8a

Lisa

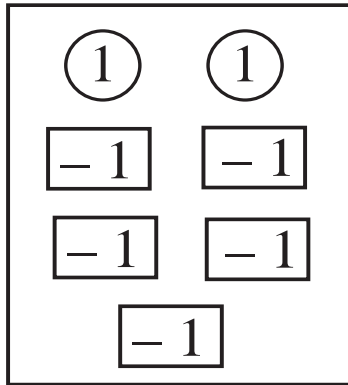

Charlie

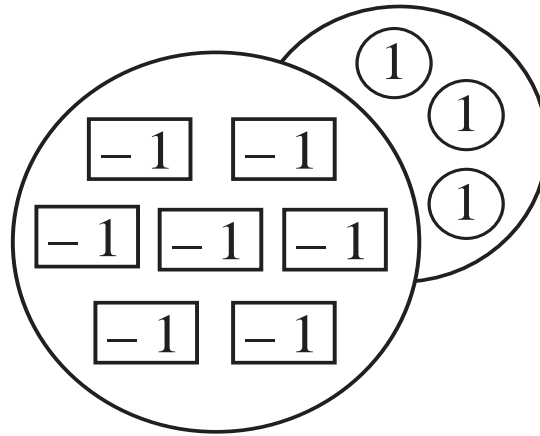

Billy

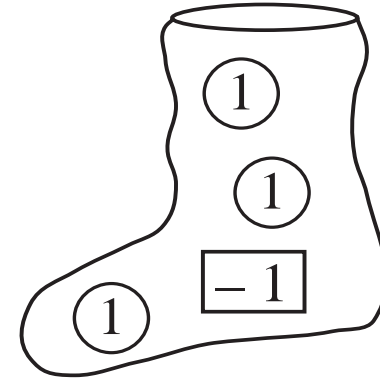

Clare

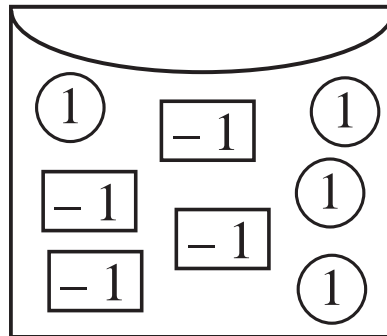

Diane

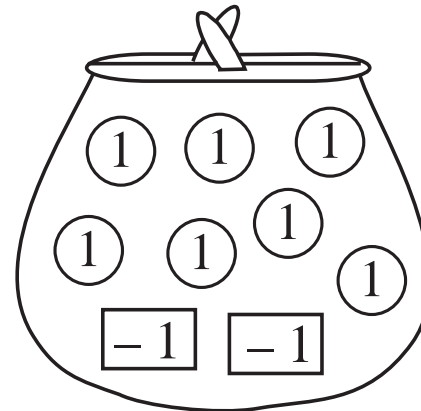

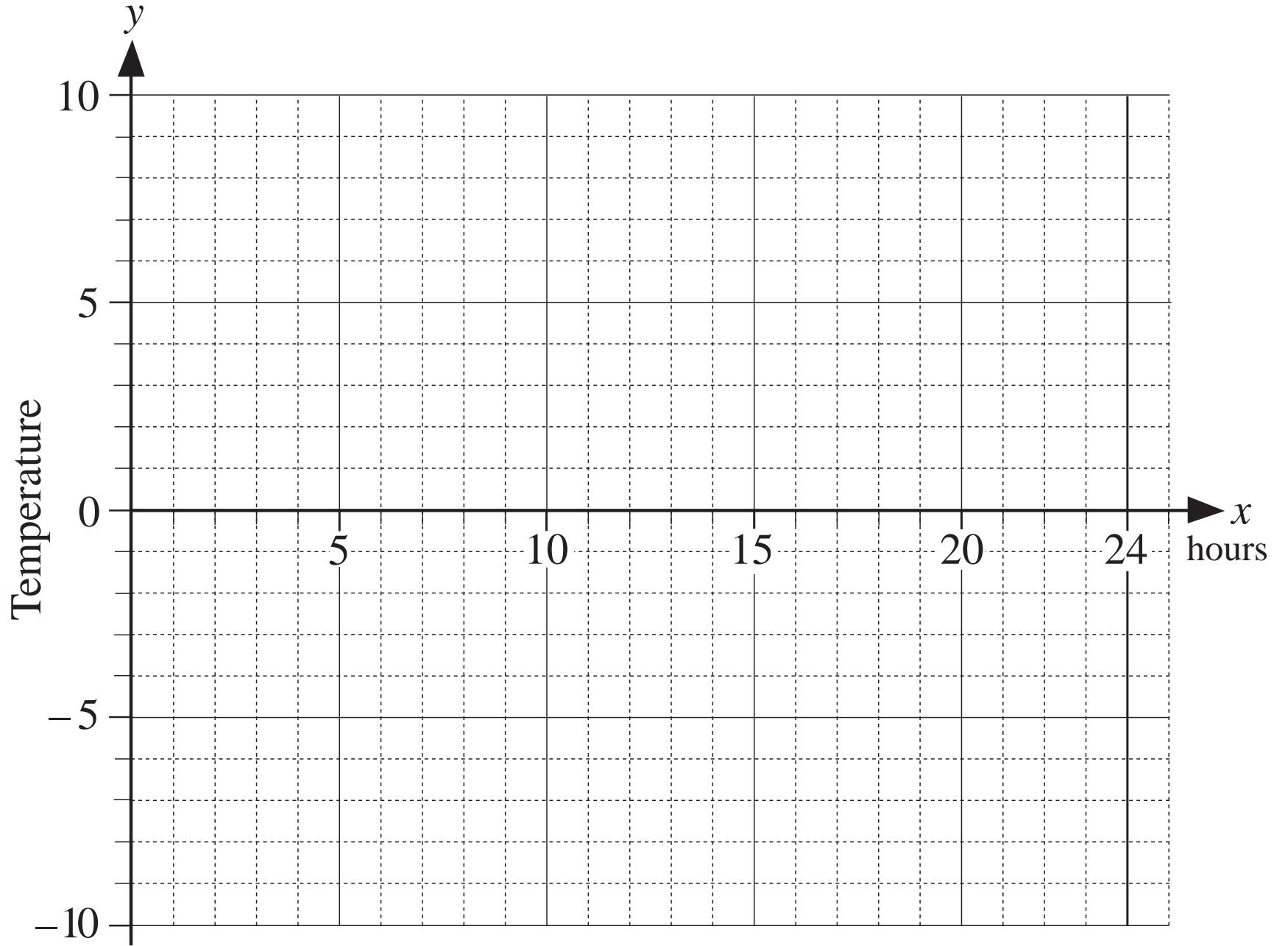
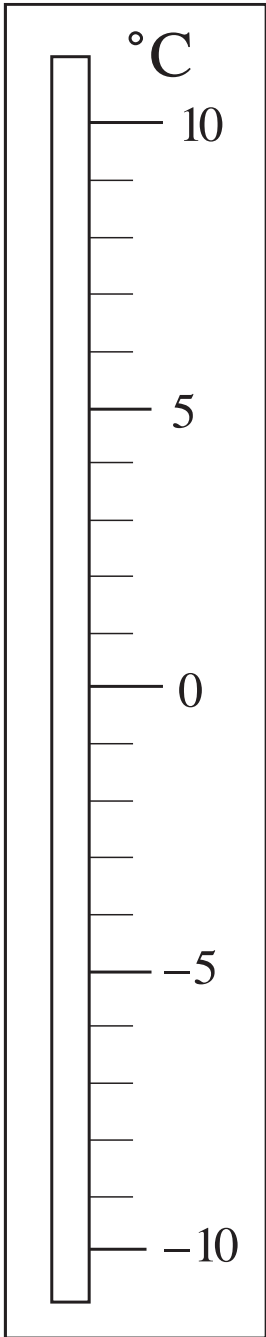

$$\text{a) } -3 < -9$$
$$6$$

$$\text{b) } -15 < -11$$
$$4$$

$$\text{c) } -8 < -2$$
$$10$$

$$\text{d) } -5 < 3$$
$$2$$

$$\text{e) } -2 > 1$$
$$1$$

$$\text{f) } -20 < 10$$
$$30$$

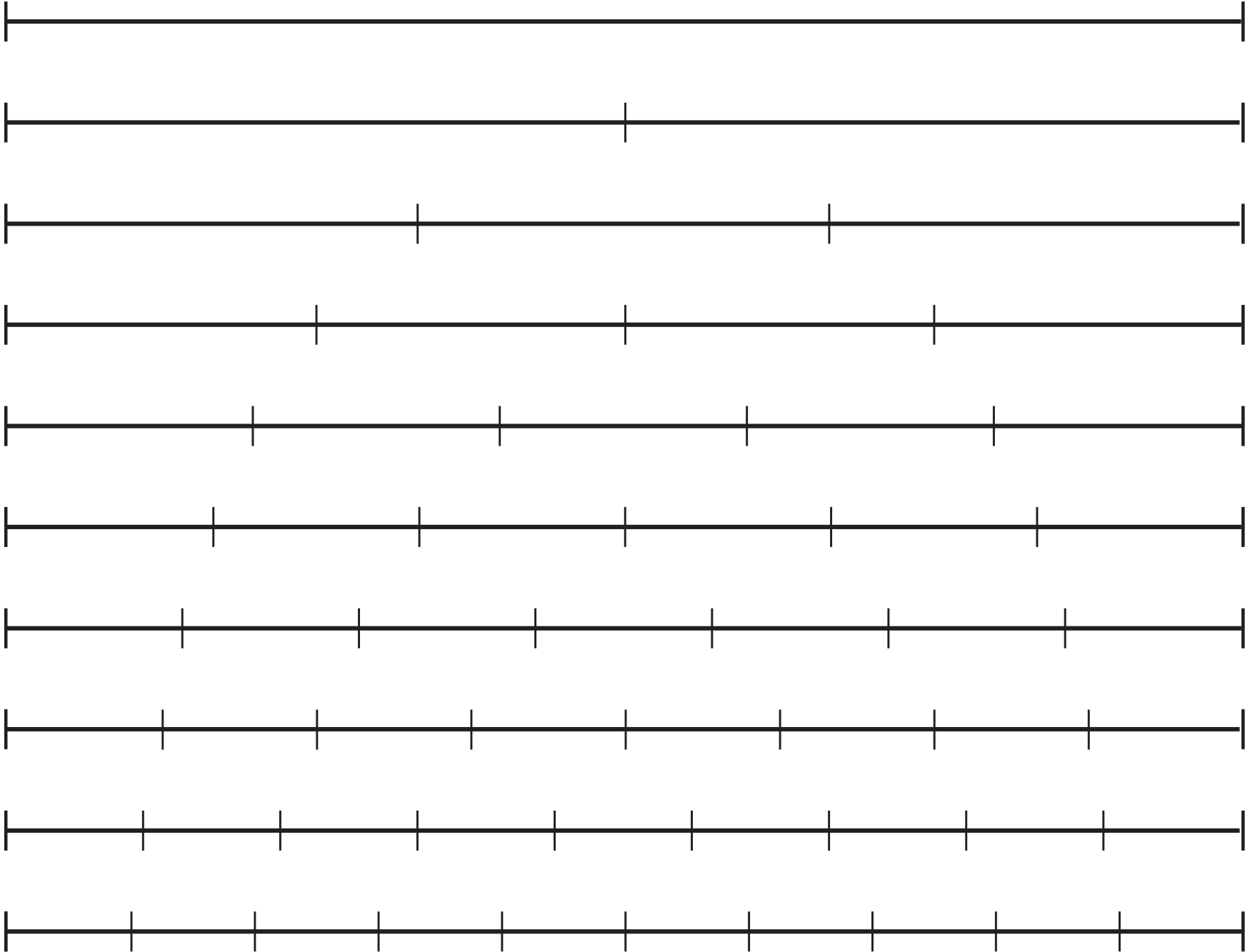

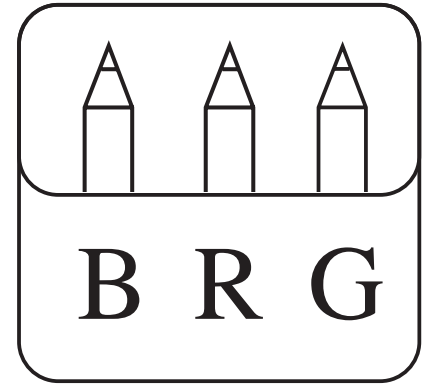

LP 131/4

A 4x10 grid of circles, each containing the number 50. Below the grid are five horizontal curly braces, each spanning one column. Below each brace is an empty rectangular box. To the right of the grid, a large curly brace groups the entire grid, and another large curly brace groups two empty rectangular boxes stacked vertically. A horizontal dashed line is positioned to the right of these two boxes.

a) $\begin{matrix} \textcircled{1} & \textcircled{1} & \textcircled{1} & \textcircled{1} \\ \textcircled{1} & \textcircled{1} & \textcircled{1} & \textcircled{1} \\ \textcircled{1} & \textcircled{1} & \textcircled{1} & \textcircled{1} \end{matrix}$

b) $\begin{matrix} \textcircled{10} & \textcircled{10} & \textcircled{10} & \textcircled{10} \\ \textcircled{10} & \textcircled{10} & \textcircled{10} & \textcircled{10} \\ \textcircled{10} & \textcircled{10} & \textcircled{10} & \textcircled{10} \end{matrix}$

c) $\begin{matrix} \textcircled{100} & \textcircled{100} & \textcircled{100} & \textcircled{100} \\ \textcircled{100} & \textcircled{100} & \textcircled{100} & \textcircled{100} \\ \textcircled{100} & \textcircled{100} & \textcircled{100} & \textcircled{100} \end{matrix}$

.....

.....

.....

.....

.....

.....

.....

.....

.....

.....

.....

.....

A:	<div style="display: flex; justify-content: space-around;"> <div style="border: 1px solid black; padding: 5px; width: 40px; height: 40px; display: flex; align-items: center; justify-content: center;">100</div> <div style="border: 1px solid black; padding: 5px; width: 40px; height: 40px; display: flex; align-items: center; justify-content: center;">100</div> </div>	<div style="border: 1px solid black; padding: 5px; width: 40px; height: 40px; display: flex; align-items: center; justify-content: center;">50</div>	<div style="display: flex; justify-content: space-around;"> <div style="border: 1px solid black; border-radius: 50%; padding: 5px; width: 30px; height: 30px; display: flex; align-items: center; justify-content: center;">5</div> <div style="border: 1px solid black; border-radius: 50%; padding: 5px; width: 30px; height: 30px; display: flex; align-items: center; justify-content: center;">2</div> </div>	}	$3 \times ($ <div style="border: 1px solid black; padding: 5px; width: 60px; height: 30px; display: inline-block; margin-right: 5px;"></div> $+$ <div style="border: 1px solid black; padding: 5px; width: 60px; height: 30px; display: inline-block; margin-right: 5px;"></div> $+$ <div style="border: 1px solid black; padding: 5px; width: 60px; height: 30px; display: inline-block; margin-right: 5px;"></div> $)$
B:	<div style="display: flex; justify-content: space-around;"> <div style="border: 1px solid black; padding: 5px; width: 40px; height: 40px; display: flex; align-items: center; justify-content: center;">100</div> <div style="border: 1px solid black; padding: 5px; width: 40px; height: 40px; display: flex; align-items: center; justify-content: center;">100</div> </div>	<div style="border: 1px solid black; padding: 5px; width: 40px; height: 40px; display: flex; align-items: center; justify-content: center;">50</div>	<div style="display: flex; justify-content: space-around;"> <div style="border: 1px solid black; border-radius: 50%; padding: 5px; width: 30px; height: 30px; display: flex; align-items: center; justify-content: center;">5</div> <div style="border: 1px solid black; border-radius: 50%; padding: 5px; width: 30px; height: 30px; display: flex; align-items: center; justify-content: center;">2</div> </div>		
C:	<div style="display: flex; justify-content: space-around;"> <div style="border: 1px solid black; padding: 5px; width: 40px; height: 40px; display: flex; align-items: center; justify-content: center;">100</div> <div style="border: 1px solid black; padding: 5px; width: 40px; height: 40px; display: flex; align-items: center; justify-content: center;">100</div> </div>	<div style="border: 1px solid black; padding: 5px; width: 40px; height: 40px; display: flex; align-items: center; justify-content: center;">50</div>	<div style="display: flex; justify-content: space-around;"> <div style="border: 1px solid black; border-radius: 50%; padding: 5px; width: 30px; height: 30px; display: flex; align-items: center; justify-content: center;">5</div> <div style="border: 1px solid black; border-radius: 50%; padding: 5px; width: 30px; height: 30px; display: flex; align-items: center; justify-content: center;">2</div> </div>		
	$3 \times$ <div style="border: 1px solid black; padding: 5px; width: 60px; height: 30px; display: inline-block; margin-right: 5px;"></div> $+$ $3 \times$ <div style="border: 1px solid black; padding: 5px; width: 60px; height: 30px; display: inline-block; margin-right: 5px;"></div> $+$ $3 \times$ <div style="border: 1px solid black; padding: 5px; width: 60px; height: 30px; display: inline-block; margin-right: 5px;"></div> $=$				
	<div style="border: 1px solid black; padding: 5px; width: 60px; height: 30px; margin: 0 auto;"></div>	<div style="border: 1px solid black; padding: 5px; width: 60px; height: 30px; margin: 0 auto;"></div>	<div style="border: 1px solid black; padding: 5px; width: 60px; height: 30px; margin: 0 auto;"></div>		

5×1

$50 \div 5$

4×3

$21 \div 3$

$25 \div 5$

10×2

$40 \div 4$

2×6

$42 \div 6$

10×10

7×5

$6 \div 2$

9×2

$63 \div 9$

$27 \div 3$

5×9

$80 \div 8$

7×3

$18 \div 6$

4×8

5×2

$35 \div 5$

6×7

$18 \div 9$

$56 \div 8$

2×3

$8 \div 2$

7×9

$18 \div 3$

10×0

a) $\textcircled{2}$ $\textcircled{2}$ $\textcircled{2}$

$\textcircled{20}$ $\textcircled{20}$ $\textcircled{20}$

$\textcircled{200}$ $\textcircled{200}$ $\textcircled{200}$

b) $\textcircled{2}$ $\textcircled{2}$ $\textcircled{2}$
 $\textcircled{2}$ $\textcircled{2}$ $\textcircled{2}$

$\textcircled{20}$ $\textcircled{20}$ $\textcircled{20}$
 $\textcircled{20}$ $\textcircled{20}$ $\textcircled{20}$

$\textcircled{200}$ $\textcircled{200}$ $\textcircled{200}$
 $\textcircled{200}$ $\textcircled{200}$ $\textcircled{200}$

a)

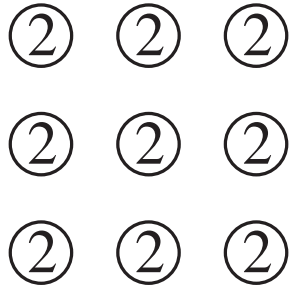

b)

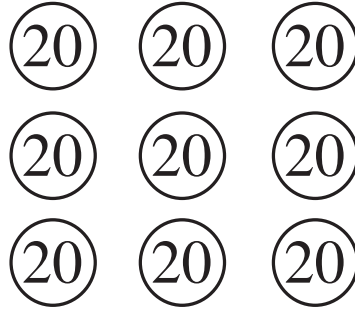

c)

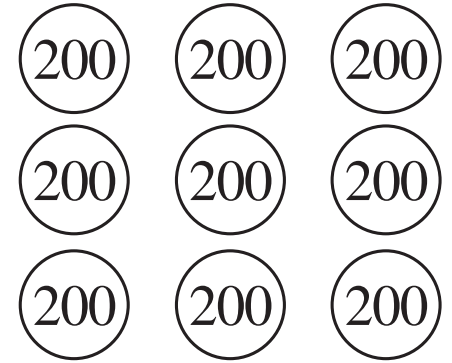

a) $5 \times 3 = \square$ $50 \times 3 = \square$ $5 \times 30 = \square$ $5 \times 300 = \square$ $50 \times 30 = \square$

b) $8 \times 2 = \square$ $80 \times 2 = \square$ $8 \times 20 = \square$ $8 \times 200 = \square$ $80 \times 20 = \square$

c) $3 \times 3 = \square$ $30 \times 3 = \square$ $3 \times 30 = \square$ $3 \times 300 = \square$ $30 \times 30 = \square$

d) $4 \times 5 = \square$ $40 \times 5 = \square$ $4 \times 50 = \square$ $4 \times 500 = \square$ $40 \times 50 = \square$

LP 132/7a

a) $5 \times 3 = \boxed{15}$ $50 \times 3 = \boxed{150}$ $5 \times 30 = \boxed{150}$ $5 \times 300 = \boxed{1500}$ $50 \times 30 = \boxed{1500}$

b) $8 \times 2 = \boxed{16}$ $80 \times 2 = \boxed{160}$ $8 \times 20 = \boxed{160}$ $8 \times 200 = \boxed{1600}$ $80 \times 20 = \boxed{1600}$

c) $3 \times 3 = \boxed{9}$ $30 \times 3 = \boxed{90}$ $3 \times 30 = \boxed{90}$ $3 \times 300 = \boxed{900}$ $30 \times 30 = \boxed{900}$

d) $4 \times 5 = \boxed{20}$ $40 \times 5 = \boxed{200}$ $4 \times 50 = \boxed{200}$ $4 \times 500 = \boxed{2000}$ $40 \times 50 = \boxed{2000}$

LP 132/7b

John

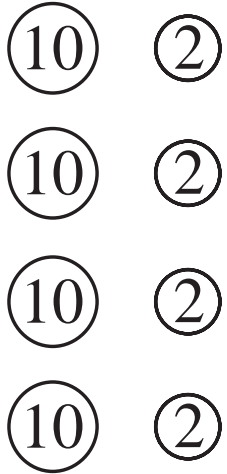

Katy

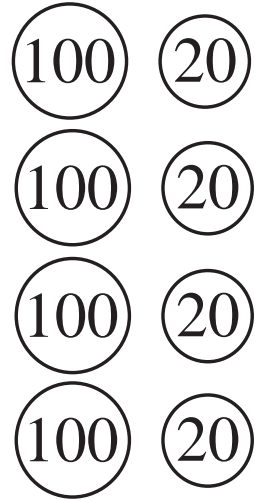

Lorna

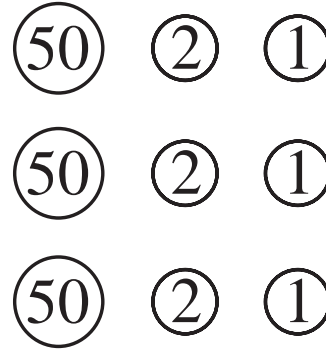

Michael

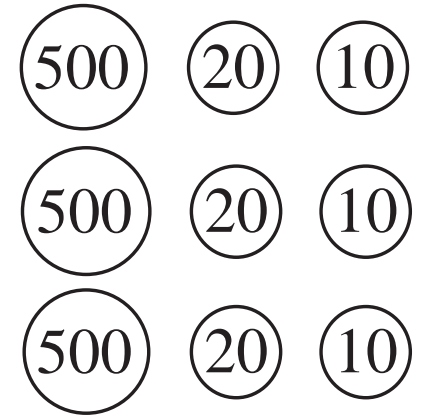

John:

Katy:

Lorna:

Michael:

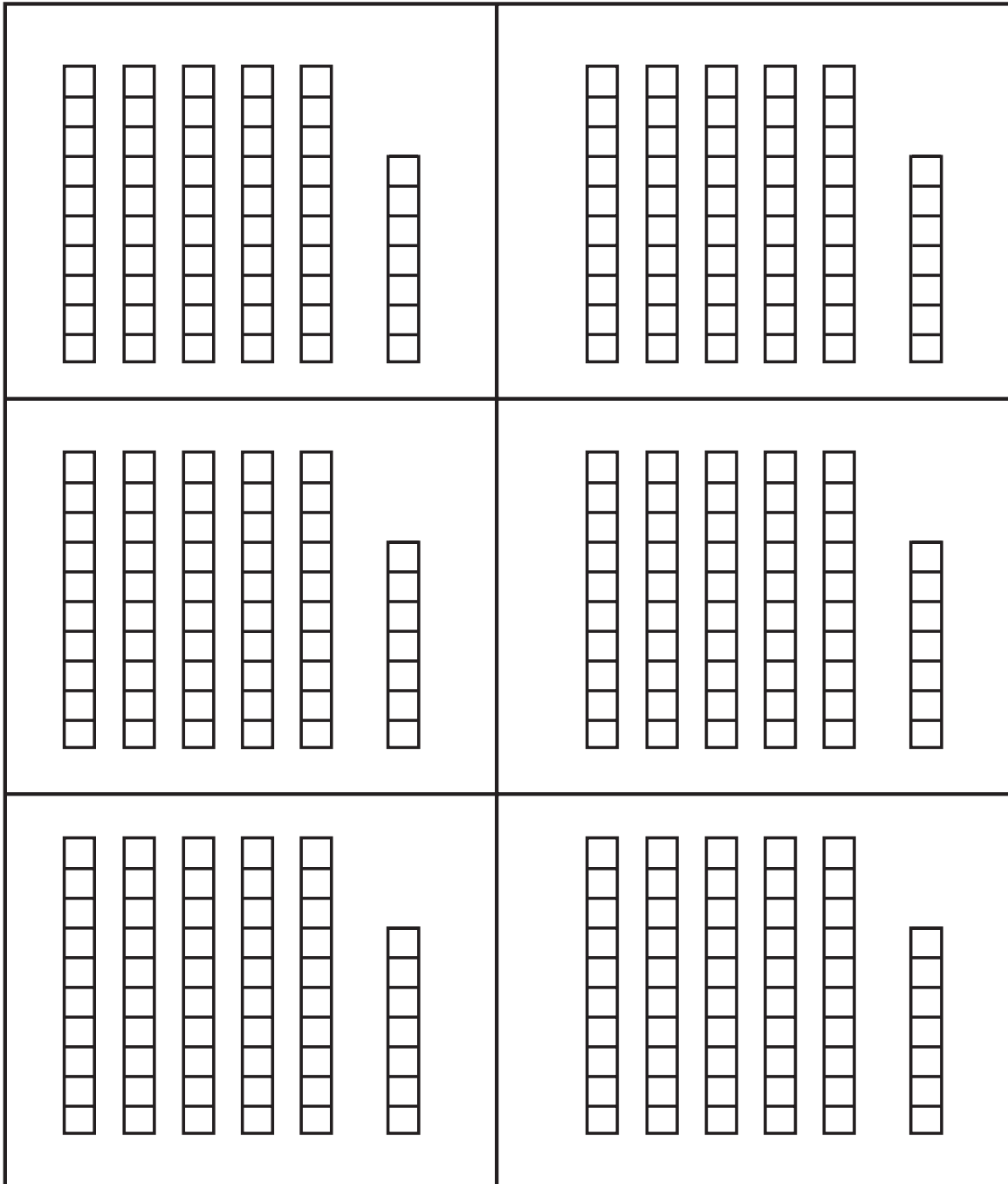

$$\begin{array}{|c|c|} \hline & \\ \hline \end{array} \times \square =$$

$$\begin{array}{|c|c|} \hline & \\ \hline \end{array} \times \square + \square \times \square$$

$$= \begin{array}{|c|c|c|} \hline & & \\ \hline \end{array} + \begin{array}{|c|c|} \hline & \\ \hline \end{array}$$

$$= \begin{array}{|c|c|c|} \hline & & \\ \hline \end{array}$$

$$\begin{array}{|c|c|} \hline & \\ \hline \end{array} \times \square = \begin{array}{|c|c|c|} \hline & & \\ \hline \end{array}$$

a) $40 \times 3 = \square$ $40 \times 6 = \square$ $40 \times 12 = \square$

b) $30 \times 4 = \square$ $30 \times 8 = \square$ $30 \times 12 = \square$

c) $50 \times 2 = \square$ $50 \times 6 = \square$ $50 \times 20 = \square$

$$\text{a) } 6 \times 28 = \square \quad 3 \times 28 = \square \quad 6 \times 14 = \square$$

$$6 \times 280 = \square \quad 3 \times 280 = \square \quad 6 \times 140 = \square$$

$$\text{b) } 4 \times 16 = \square \quad 8 \times 8 = \square \quad 2 \times 32 = \square$$

$$4 \times 160 = \square \quad 8 \times 80 = \square \quad 2 \times 320 = \square$$

$$\text{c) } 6 \times 16 = \square \quad 6 \times 15 = \square \quad 5 \times 15 = \square$$

$$6 \times 160 = \square \quad 6 \times 150 = \square \quad 5 \times 150 = \square$$

a) 227×4

i) Rounding 227 to the nearest hundred:

$$P \approx \boxed{} \times 4 = \boxed{} \quad P \bigcirc \boxed{}$$

ii) Rounding 227 to the nearest ten:

$$P \approx \boxed{} \times 4 = \boxed{} \quad P \bigcirc \boxed{}$$

b) 468×6

i) Rounding 468 to the nearest hundred:

$$P \approx \boxed{} \times 6 = \boxed{} \quad P \bigcirc \boxed{}$$

ii) Rounding 468 to the nearest ten:

$$P \approx \boxed{} \times 6 = \boxed{} \quad P \bigcirc \boxed{}$$

a) $162 \times 5 \approx \square \times 5 = \square$ $162 \times 5 \bigcirc \square$

b) $177 \times 4 \approx \square \times 4 = \square$ $177 \times 4 \bigcirc \square$

c) $315 \times 3 \approx \square \times 3 = \square$ $315 \times 3 \bigcirc \square$

d) $231 \times 4 \approx \square \times 4 = \square$ $231 \times 4 \bigcirc \square$

100

100

20

10

20

10

5

5

Make two copies on card.

a)

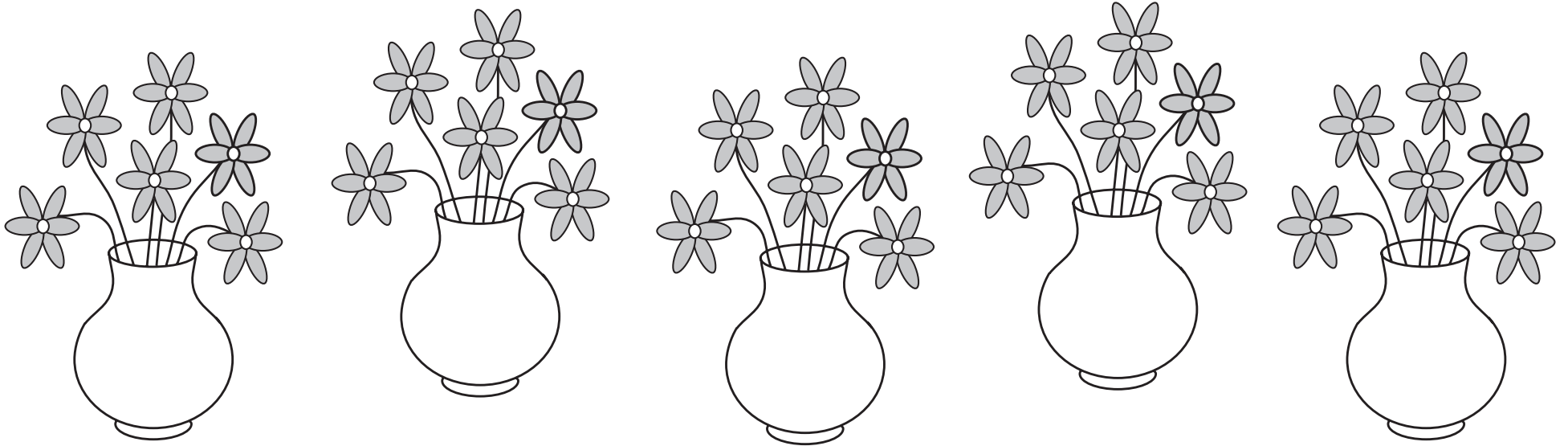

b)

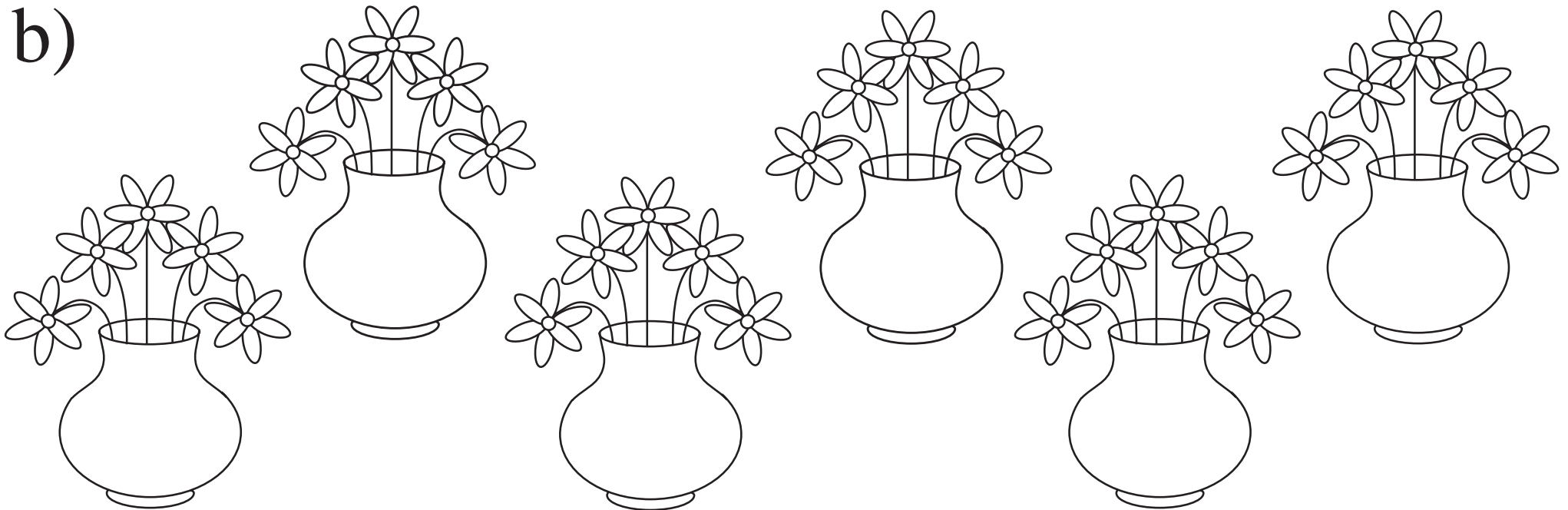

$$436 \times 5$$

$$436 \times 5$$

$$436 \times 5$$

$$436 \times 5$$

1800

2000

2400

2100

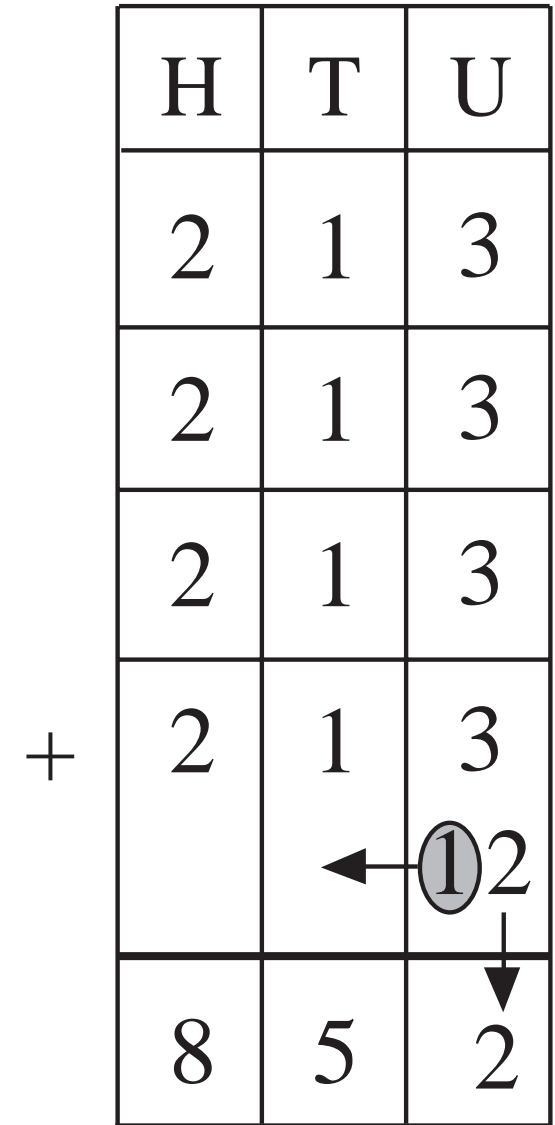
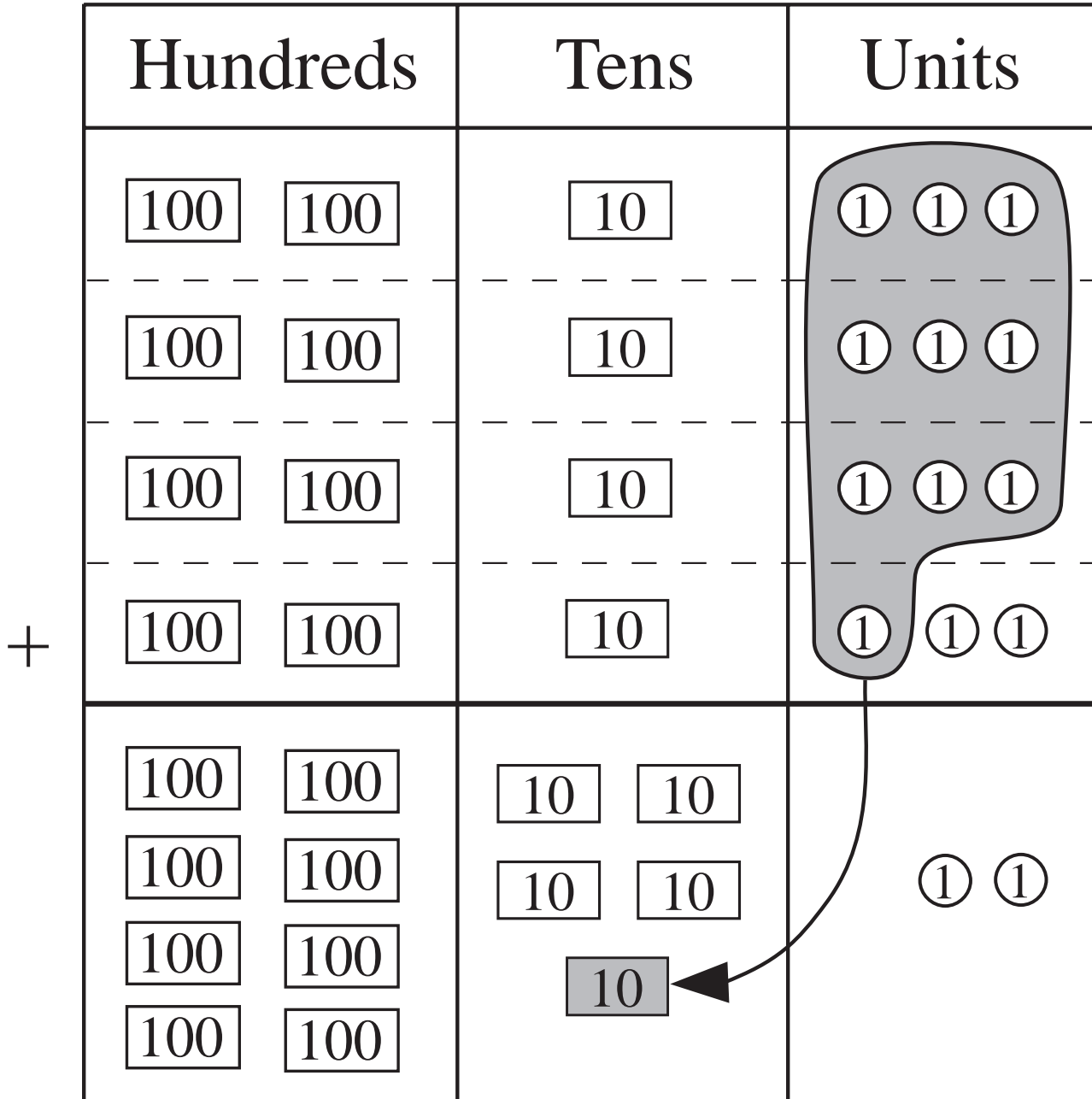

	H	T	U
	2	1	3
	2	1	3
	2	1	3
+	2	1	3
	8	5	2

H	T	U	
2	1	3	× 4
8	5	2	

2	1	3	× 4
8	5	2	

Hundreds	Tens	Units
100		

H	T	U

+

H	T	U

 $\times 3$

 $\times 3$

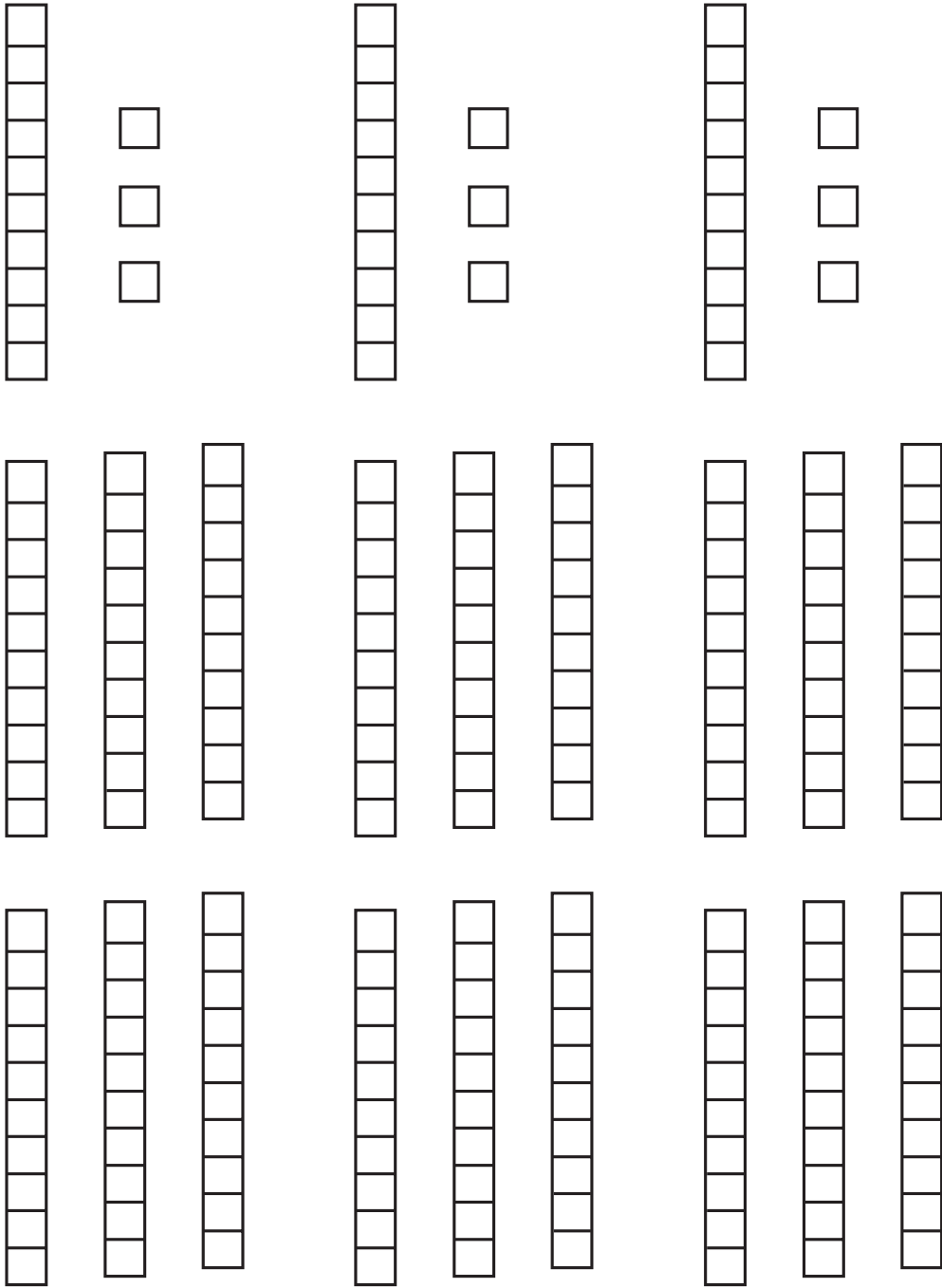

$$73 \times 3 =$$

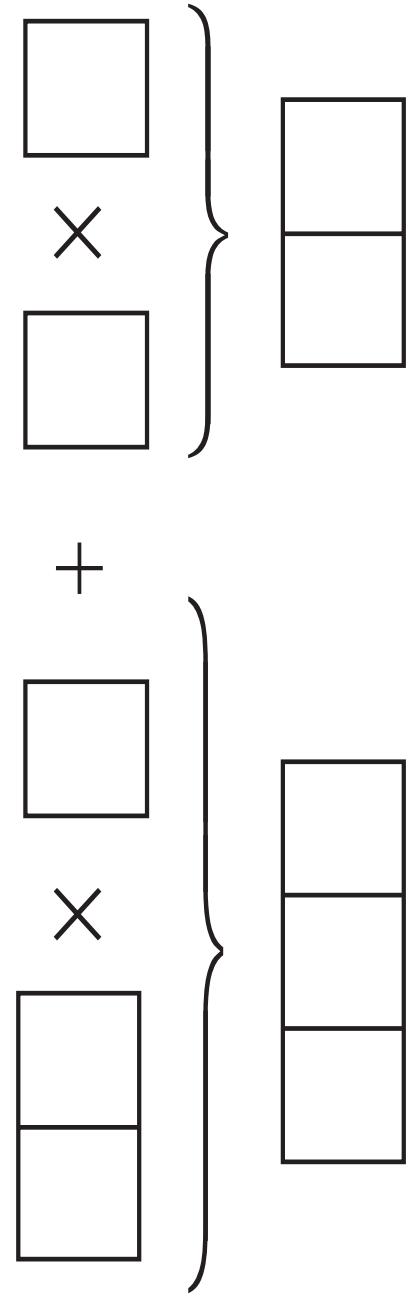

a)

	2	0	2
	2	0	2
	2	0	2
+	2	0	2
<hr/>			

E:

--	--	--	--

	2	0	2	×	
<hr/>					

b)

	3	0	2
	3	0	2
+	3	0	2
<hr/>			

E:

--	--	--	--

	3	0	2	×	
<hr/>					

c)

	4	2	3
+	4	2	3
<hr/>			

E:

--	--	--	--

	4	2	3	×	
<hr/>					

d)

	2	0	1
	2	0	1
	2	0	1
	2	0	1
+	2	0	1
<hr/>			

E:

--	--	--	--

	2	0	1	×	
<hr/>					

a)

H	T	U		
	8	2	×	4

b)

H	T	U		
	9	1	×	7

c)

H	T	U		
	6	2	×	3

d)

H	T	U		
	6	2	×	4

e)

H	T	U		
	9	1	×	8

f)

H	T	U		
	1	2	×	4

g)

Th	H	T	U		
	3	2	1	×	3

h)

Th	H	T	U		
	3	2	1	×	4

i)

Th	H	T	U		
	5	2	3	×	3

j)

Th	H	T	U		
	4	0	2	×	4

k)

Th	H	T	U		
	4	0	3	×	4

l)

Th	H	T	U		
	6	1	2	×	3

<i>a</i>	423	211	322	323	514	73	441
<i>b</i>	2	5	4	3			
<i>c</i>	846	1055			1028	219	882

a) *E:*

	4	2	3
	4	2	3
+	4	2	3

	4	2	3	×	

 b) *E:*

	3	2	1
	3	2	1
	3	2	1
+	3	2	1

	3	2	1	×	

 c) *E:*

	3	0	9
	3	0	9
+	3	0	9

	3	0	9	×	

 d) *E:*

	1	4	1
	1	4	1
	1	4	1
	1	4	1
	1	4	1
	1	4	1
+	1	4	1

	1	4	1	×	

a)

	7	1
	7	1
	7	1
	7	1
	7	1
+	7	1

E:

	7	1	×	6

b)

E:

	2	0	1
	2	0	1
	2	0	1
+	2	0	1

	2	0	1	×	

c)

E:

	5	3	4
+	5	3	4

	5	3	4	×	

d)

E:

	2	1	1
	2	1	1
	2	1	1
	2	1	1
+	2	1	1

	2	1	1	×	

a) $E:$

--	--	--

4	2	2	×	2

$E:$

--	--	--	--

	4	2	2	×	3

$E:$

--	--	--	--

	4	2	2	×	4

b) $E:$

--	--	--

3	2	1	×	3

$E:$

--	--	--	--

	4	2	1	×	3

$E:$

--	--	--	--

	6	2	1	×	3

c) $E:$

--	--	--

	8	4	×	2

$E:$

--	--	--	--

	8	0	4	×	2

$E:$

--	--	--	--

	4	0	2	×	4

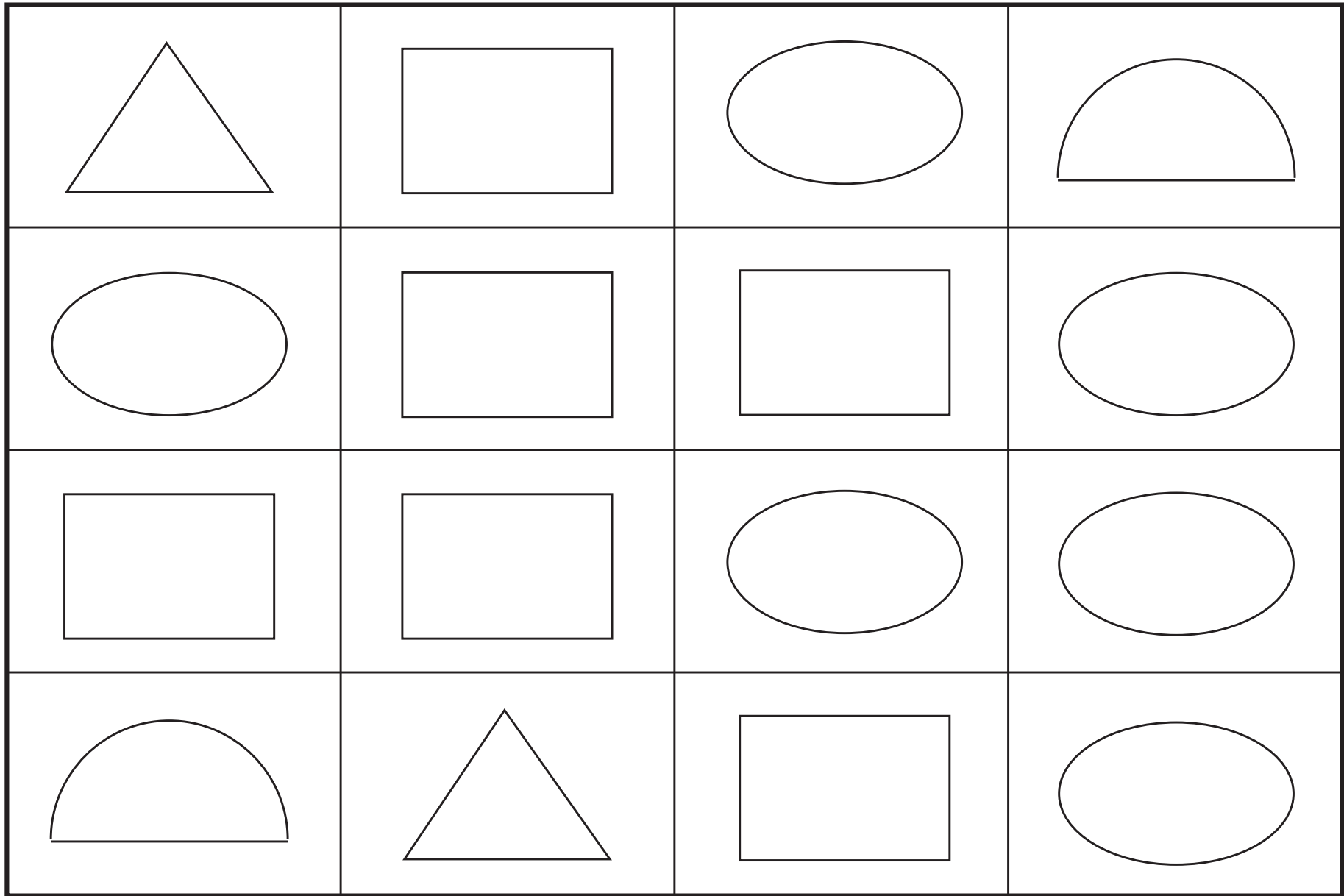

a	b	c	$a \times c$	$a \times b$	$b \times c$
400	5	3			
450	6	4			

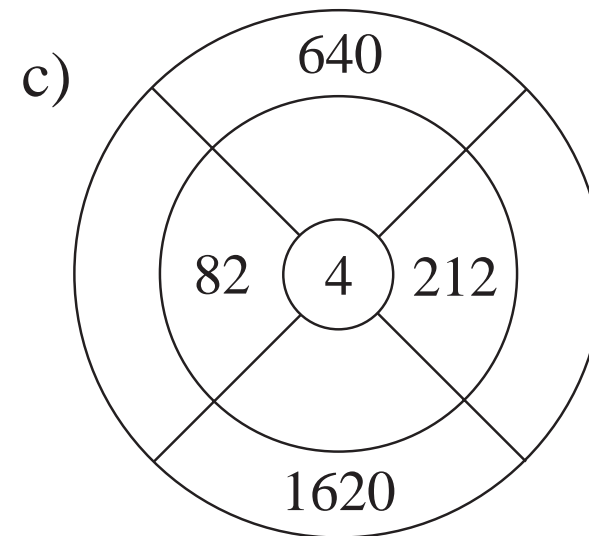
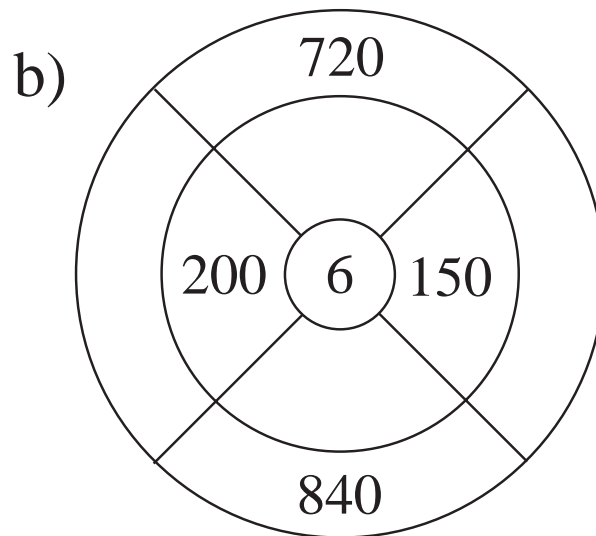
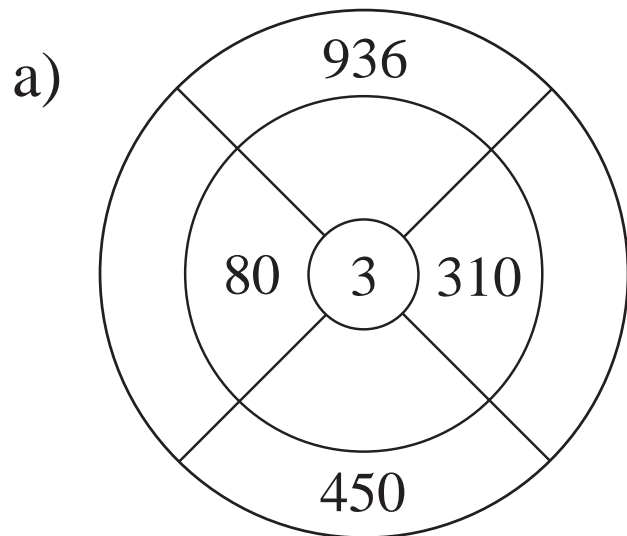

LP 138/4

a)

		6	4	×	3
1	8	1	2		

b)

	5	0	2	×	3
	1	5	6		

c)

	4	6	4	×	3
1	3	9	2		

d)

	1	7	0	×	3
5	1	3			

e)

	4	0	5	×	3
2	2	1	5		

f)

	3	1	6	×	4
1	2	4	4		

LP 138/5

a)

	2	6	×	5

	5	2	×	6

	4	4	×	4

1	0	6	×	9

b)

	4	4	2	×	2

	2	0	8	×	7

	4	0	7	×	3

	3	0	5	×	0

c)

	2	0	7	×	9

	1	1	6	×	6

	2	7	5	×	1

	3	0	7	×	6

a)

			×	2		
8	2	6				

			×	3		
9	6	3				

2	3	4	×			
4	6	8				

1	0	6	×			
6	3	6				

b)

			×	3		
6	1	2				

			×	4		
8	6	4				

1	3	5	×			
2	7	0				

2	1	7	×			
8	6	8				

c)

			×	4		
6	0	8				

			×	5		
8	5	5				

1	5	1	×			
9	0	6				

1	8	3	×			
5	4	9				

a)

2	3	×	2
			0

3	2	×	3
			6

b)

	2	3	×	<input type="text"/>
8				2

	6	×	5
8			0

c)

3		×	3
	4		2

	8	×	6
4			8

d)

	9	×	<input type="text"/>
9	8		1

	8	3	×	<input type="text"/>
6				4



Time (seconds)	1	2	5	0	4	10
Distance (mm)	217					